

Portland State University

PDXScholar

---

RAIN: Journal of Appropriate Technology

RAIN

---

12-1976

## RAIN: Journal of Appropriate Technology

ECO-NET

Follow this and additional works at: [https://pdxscholar.library.pdx.edu/rain\\_japt](https://pdxscholar.library.pdx.edu/rain_japt)

Let us know how access to this document benefits you.

---

### Recommended Citation

ECO-NET, "RAIN: Journal of Appropriate Technology" (1976). *RAIN: Journal of Appropriate Technology*. 28.

[https://pdxscholar.library.pdx.edu/rain\\_japt/28](https://pdxscholar.library.pdx.edu/rain_japt/28)

This Book is brought to you for free and open access. It has been accepted for inclusion in RAIN: Journal of Appropriate Technology by an authorized administrator of PDXScholar. Please contact us if we can make this document more accessible: [pdxscholar@pdx.edu](mailto:pdxscholar@pdx.edu).



# RAIN

Journal of Appropriate Technology

DECEMBER 1976

VOL. III, NO. 3

ONE DOLLAR



Oregon Journal photo by David Weintrub

**INSIDE: AMORY LOVINS on over-electrification p.4**  
**E. F. SCHUMACHER**  
**on technology and political change p.8**  
**GRAPHICS p.12**



# RAIN *access*

## BUILDING

**Stone Masonry**, Ken Kern, Steve Magers, Lou Penfield, \$6 from:

Owner-Builder Publications  
Box 550  
Oakhurst, CA 93644

First of a new series of guides for beginning builders being prepared by Kern's press. Beautifully illustrated with clear photographs, this volume covers the basics of stability; choosing, fitting and shaping stone; laid, faced and formed stonework; and details of steps, arches, fireplaces, scaffolding and other operations. At the same time, it gives a sense of the beauty of different kinds of stonework and how to think ahead to how what you're doing will turn out. A beginner's, not a stonemason's, guide, but good for that purpose.

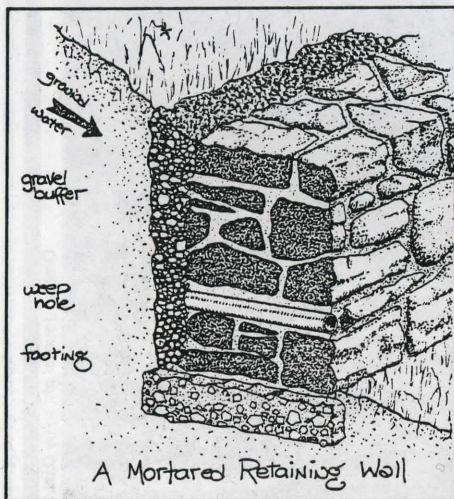

**Private Water Systems**, \$2.50 from:

Midwest Plan Service  
207 Davidson Hall  
Iowa State University  
Ames, IA 50011

If you're going to do your own water system, this is the guide to get. Detailed information on determining how much water you need, pros and cons of different water sources, choosing pumps and equipment, planning and calculating a water system, and various water treatment techniques.



**Handbook for Building Homes of Earth**, free from:

Office of International Affairs  
Department of Housing and Urban Development  
Washington, DC 20410

A real bargain, even if you had to pay for it. Goes on your bookshelf right next to Middleton's *Build Your House of Earth*. Simple, clear, how-to information for building earth homes—soil testing, site preparation, details of adobe, pressed block, rammed earth, earth roofs and floors, and surface coatings. Excellent illustrations. Better how-to than Middleton's book but fewer design examples and case studies of problems. It's a strange route that highway engineer's soil mechanics takes back into knowledgeable building of earth homes! More details on oil-stabilized earth floors and some other techniques can be found in the earlier *Earth for Homes*, 1955, from the same office.

**Don't Go Buy Appearances**, George Hoffman, \$2.95 from:

Woodward Books  
Box 773  
Corte Madera, CA 94925

A manual for checking out and evaluating a house before purchase. A lot of good specific advice on how to find out if the furnace boiler is about rusted out, what the electrical capacity of the house is, whether the leaky faucet is a major or minor problem and how to tell quality and what it means in your pocket-book over 40 years. More importantly, how to figure if fixing the problems are major or minor undertakings.

**Velux Roof Windows**  
Velux-America Inc.  
80 Cummings Park  
Woburn, MA 01801

Roof windows are a good approach to pulling a lot of sun heat and light into

a building, renovating and using attics in old houses for more efficient space use and not having to build complex and expensive dormers into a roof. Get the information from these folks—showing a lot of varied applications, how to flash to prevent leaks and how to deal with the new problems of sloping windows! Whether you use their products or make your own, it's a good idea. If they would come out with a sliding insulating shutter similar to their decorative one, I'd give them our four-dandelion award.

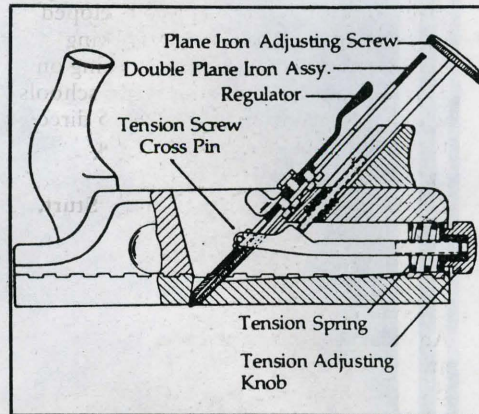

**Woodcraft Catalog**, 50¢ from:  
Woodcraft Supply Corp.  
313 Montvale Ave.  
Woburn, MA 01801

A connoisseur's guide to woodworking tools—if you think you need Cadillacs. You'll have to pay for it. Sometimes, though, you want to find out if the tool or the person makes the difference. From here you can get and try out Swiss carving tools, Japanese saws, shipbuilder's adze, bark spuds, broad axes, German/French/English/American drawknives—you name it. Next time you will make it yourself. The catalog is a learning experience in itself.

**Minnesota Woodworkers Supply Co.**  
Industrial Blvd.  
Rogers, MN 55374

Woodcraft supplies tools, Minnesota Woodworkers supplies all sorts of hard-to-find specialty hardware—plans, upholstery supplies, lamp parts, furniture trim, carvings, hinges and locks, veneers and inlays.

—Tom Bender



RAIN is a monthly information access journal and reference service for people developing more satisfying patterns that increase local self-reliance and press less heavily on our limited resources.

We try to give access to:

- \* Solid *technical support* for evaluating and implementing new ideas.
- \* *Ecological and philosophical perceptions* that can help create more satisfying options for living, working and playing.
- \* *Up-to-date information* on people, events and publications.

## LEARNING

**Applesauce**, \$5/yr. from:  
National Alternative Schools Program  
School of Education  
University of Massachusetts  
Amherst, MA 01002

A nice newsprint format self-described as "a blend of ideas and happenings in alternative education." The latest issue included a mammoth resource listing compiled by Miriam Wasserman and Linda Hutchinson of the Education Exploration Center in Minneapolis. The next issue will focus on vocational education and some curriculum developed by an alternative school for working class women. They are also working on a '76-'77 directory of alternative schools which, judging from their '75-'76 directory, should be worth waiting for. (LdeM)

**The Wheelwright's Shop**, George Sturt, 1923, \$6.95 from:  
Cambridge University Press  
32 E. 57th Street  
New York, NY 10022

An autobiographical account of operating a wheelwright shop in England in the late 1800s, but of greater value as a guide to the value of apprentice learning and learning by doing. The book gives a strong sense of how interdependent the designs of things become and how much greater valued are the skills of workers when there isn't so much wealth that everything can be overdone. So many things we do seem rude and awkward that it's good to get a sense of how things become more mellow and well-fitting when enough time has passed to work off the rough edges and find more complete solutions to problems. (TB)

**Innovative Graduate Programs Directory**, 2nd Edition, April 1976, cost unknown, available from:

Learning Resources Center  
Empire State College  
Saratoga Springs, NY 12866

In 1970-71 I published an alternate community weekly newspaper in Miami, Florida. We maintained a post office box and got on many unusual mailing lists. After the paper ceased publication, we kept the post office box and continued to receive mail. In 1974, while working as a researcher and community liaison on a public tv show for older

people, I received an announcement in the post office box proclaiming a new master's degree program called Community Information Specialist. My god, I thought, that's what I am—I never knew what to call myself. And off I went.

Now there's an easier way to find a graduate program attuned to the times. This *Directory*. It's not all-inclusive, and the descriptions are incomplete (mostly from the college catalog), but it's a good place to start. The uniqueness of the programs included (in over 200 subject areas ranging from adult education to water resources management) are either graduate credit being given in a new field or external degrees in traditional fields.

While there have been guides to alternate schools and colleges, this is the first listing of experimental graduate programs, most of them on the master's degree level. The directory is arranged alphabetically by name of college or university, with a subject index referring you to the school with a program in that field. (RE)

### Master of Science in Biomedical Communications

College of Medicine  
University of Cincinnati  
231 Bethesda Ave.  
Cincinnati, OH 45267  
513/872-5652

Joe Bakan

A new program begun in fall of 1976 training communications specialists in health care education and delivery systems to assist in the interaction between health professionals and patients. Study areas include: health care environment and delivery systems, media, learning theory and instructional methods, applied behavioral science and communications and behavioral measurement, statistics and research design. (RE)

### Master of Science in Ecosystem Management

Farallones Institute/Antioch College  
West  
1516 Fifth St.  
Berkeley, CA 94710  
415/524-1150  
Helga Olkowski

This is as close as anything comes to being a graduate education program in appropriate technology. It is conducted by Farallones and accredited through

Antioch College.

"Developed to create a professional level manager-planner who has an understanding of basic principles in biology and ecology, who has skills in methods of manipulating the plant-animal-human interface, and who can operate with knowledge of social needs and economic realities. The focus is on the ecosystem because this concept ties together organisms, their needs and their life-supporting environments. The term management is used to imply the use of intelligent methods to affect changes in ecosystems but not to dominate or control. Planning concerns both design and administrative functions. A strong base in systems theory is included so as to maximize the use of integrated ideas from many disciplines in design and program development."

The program is looking for students who are "capable of independent study, who have at least an elementary knowledge of biology, who are committed to using scientific methods of investigation and who are interested in ecological problems and motivated by a desire to affect social change through developing and implementing environmentally sound solutions." (RE)

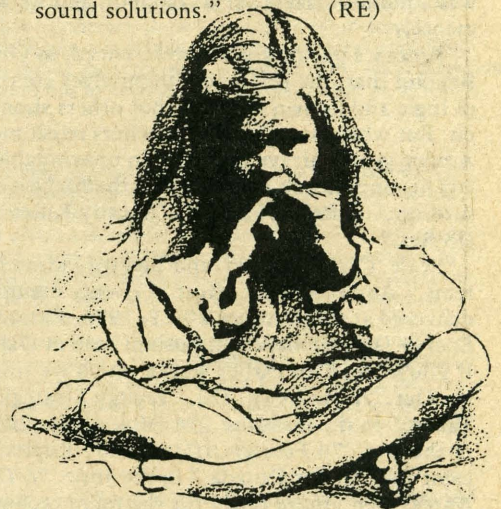

**Cricket Monthly**, \$10/9 issues, from:  
Walnut Lane  
Boulder, CO 80301

A good children's magazine with stories, a few poems, project suggestions and creative writing and drawing contests. Because selections are designed for 5-12-year-olds, *Cricket* would be good to have in a school library or a family with more than one child in this age bracket. (Lauri deMoll)



# THE SECOND LAW OF THERMODYNAMICS SAYS CUTTING BUTTER WITH A NUCLEAR-ELECTRIC CHAINSAW DOESN'T MAKE SENSE AND HAS GOT TO STOP

We keep telling you that Amory Lovins is someone all of you out there ought to begin paying attention to. I first perked up my ears to him and got deep into his work at the '75 "Limits to Growth" conference in Houston, Texas. There we were, in the heart of the fossil-fueled dinosaur, the deep-carpeted (petroleum-based), plush-seated, Woodlands resort and meeting center . . . and Amory was listening intently to Harry Bovay, board chairman of Bovay Engineers, engineer emeritus and fellow panelist, as Harry condescendingly explained why nuclear electricity was the only way to go. But the match was a bit unfair, for Harry was unwittingly supplying Amory with all the facts and figures he needed to produce a withering return volley. Quick as a flash, Amory drew his pocket calculator, took aim at the dinosaur, and shot it with his own data. A standing-room-only crowd watched Harry's head roll, figuratively, and turn beet-red, literally, and burst into cheers. For it was a modern David versus Goliath, and we enjoyed it immensely.

Amory's papers are well-referenced, as you would expect. Beyond that, the references themselves are often minor gems of logic and human concern that others should follow up on. But what many Lovins-watchers relish most is the way Amory gently arrays the truth in unavoidable simplicity. He lets his opponent's claims reveal themselves in their full absurdity . . . "Relax," he says, "Ready Killer-Watt has no clothes."

"Scale, Centralization, and Electrification in Energy Systems," Amory's latest effort at energy common sense, was delivered at the October 20-21, 1976, *Future Strategies for Energy Development* symposium held at Oak Ridge, Tennessee. If you've read his earlier works which we told you about in the Oct. '76 RAIN (p. 18), "Energy Strategy: The Road Not Taken," in the mid-Nov. '76 (Vol. 6, No. 20) *Not Man Apart* or the Oct. '76 *Foreign Affairs*, and "Exploring Energy-Efficient Futures for Canada," in the June '76 *Conservation Society Notes*, then you're ready for the more technical and full-of-numbers Oak Ridge paper. It will prove very useful to citizen energy organizations, nuclear plant siting intervenors and anti-utility rate hike groups. And it's just plain fun to read.

We've selected excerpts from the Oak Ridge paper that might be considered Amory's responses to the Bonneville Power Administration's latest "non-policy trial balloon." BPA may contract in advance to buy power from private utilities who are unable to get loans and sell stock as cheaply or easily as before. With such secure, federally-backed contracts in hand, private power companies can easily get low interest

loans for continuing construction of large-scale electrical power plants. This is what Lovins calls the "hard path" of high energy, primary-supply-oriented, high technology, centralized, increasingly electrified, and reliant chiefly on depletable coal and uranium resources.

If existing centralized systems do not now make economic and engineering sense, why were they built? There are at least four rational explanations. First, because objective conditions have changed drastically, and an industry not noted for quick and imaginative responses has been slow to adapt. Second, because centralized energy systems have been built by institutions in no position to ask whether those systems are the best way to perform particular end-use functions—an omission reinforced by our failure to price fuels at long-run marginal cost. Third, at times we have seen powerful institutions deliberately seeking to reinforce their power by constricting consumer choice, as in the classic monopoly tactics of the early electric utilities or the fight against public power and (abroad) private wind machines. Fourth, the long economic shadow cast by large sunk costs has often led us to seek to reinforce past mistakes through subsidies, bailouts, \$100-billion slush funds, etc., thus further restricting consumer choice, rather than writing off (or gradually retiring through attrition) ill-conceived infrastructure. Energy decisions are always implemented gradually and incrementally; major shifts take decades. A chief element of strategy, inherent in the soft path, is thus to avoid incremental commitments of resources to major infrastructure that locks us into particular supply patterns for more decades thereafter. We are already stuck with gigantic infrastructure that constrains our choices, and nobody is suggesting we wipe the slate clean. The question is rather what we do at the margin. What made sense on the up-side of the Hubbert blip, when real costs of electricity (both average and marginal) were steadily falling, may need to be reversed on the down-side of the blip and when real costs are rapidly rising with no end in sight.

The illogic of the ERDA position is this: if we are running out of oil and gas but do not like coal, it is said, we need nuclear power; but if we are not going to have nuclear power, we need other systems that would do what nuclear stations would have done—namely, deliver GW blocks of electricity. But we should instead be seeking systems that will do what we would have done with the oil and gas if we had had them in the first place. It is the function that interests us, not substituting for reactors. By not structuring the problem in this way, ERDA has so far failed to grasp the immense short- and medium-term opportunities for deploying available technologies for end-use efficiency, cogeneration, fluidized-bed boiler backfits, organic conversion, and extensive solar space heating. The longer this delay, the worse will be our shortages of clean heat and fluid fuels. I hope that the discussion arising from this Symposium will increase ERDA's awareness of the existence of coherent non-electrified views of our energy future.

In a soft energy path, the technological measure to be achieved can be readily separated from the policy instrument used to encourage it. The former—cogeneration, bioconversion, insulation—is neutral, the latter politically charged. It is the latter only that is likely to irritate us if ill-conceived. But I believe the policy tool can be chosen, accord-



ing to practical and ideological convenience, from such an enormous armamentarium that the choice can fully respect pluralism and voluntarism.

I do not see how the same pluralism can possibly extend to a hard, coarse-grained energy path. The scale and the technical difficulty of its enterprises are so vast that corresponding concentrations of social resources must be efficiently mobilized without substantive regard to diverse opinions and circumstances. Only large corporations, encouraged by large government agencies, using large sums of private and public money to employ large numbers of workers on large areas of land, can possibly get the job done. It is not a task for householders, small businesses, block associations or town meetings.

Soft technologies are thus inherently, structurally less coercive and more participatory than hard technologies. In a nuclear society, nobody can opt out of nuclear risk. In an electrified society, everyone's lifestyle is shaped by the economic imperatives of the energy system, and, from the viewpoint of the consumer, diversity becomes a vanishing luxury. Like purchasers of model T Fords, the consumer can have anything he wants so long as it's electrified. But in a soft path, each person can choose his own risk-benefit balance and his own energy systems to match his own degree of caution and involvement. People who do not care to partake of the advantages of district heating will be free to reject them—and, if the system is thoughtfully designed, to change their minds later. People who want to drive big cars or inhabit uninsulated houses will be free to do so—and to pay the social costs. People can choose to live in city centers, remote countryside, or in between, without being told their lifestyle is uneconomic. People can choose to minimize their "consumer humiliation"—their forced dependence on systems they cannot understand, control, diagnose, repair, or modify—or can continue to depend on traditional utilities, for large grids are already with us and in some degree will persist for a long time. In a soft path, then, dissent and diversity are not just a futile gesture but a basis for political action and a spur to private enterprise. But the monolithic nature, gargantuan scale, exacting requirements, and homogenizing infrastructure of hard technologies does not offer such pluralism. Only our largest conglomerations of resources, shielded by the powers of the state from the vagaries of the economic and political marketplace, can perform such demanding tasks.



Centralized energy systems are also inequitable in principle because they separate the energy output from its side-effects, allocating them to different people at opposite ends of the transmission lines, pipelines, or rail lines. The export of these side-effects from Los Angeles and New York to Navajo country, Appalachia, Wyoming, and the Brooks Range (not to mention Venezuela, the Caribbean, Kuwait, and British Columbia) makes the former more habitable and the latter more resentful. That resentment is finding political expression. As the weakest groups in society, such as the native peoples, come to appear to stronger groups as miners' canaries whose fate foretells their own, sympathy for the recipients of the exported side-effects grows.

Throughout the world, central government is trying to promote expansionist energy policies by preempting regulatory authority, and in the process is eliciting a strong State (or Provincial) and local response. Washington, Ottawa, Bonn, Paris, and Auckland are coming to be viewed locally as the common enemy. Unholy alliances form. Perhaps Montana might mutter to Massachusetts, "We won't oil your beaches if you won't strip our coal." As Congress—made of State people with no Federal constituency—increasingly molds interregional conflict into a common States'-rights front, decisions gravitate by default to the lower political levels at which consensus is still possible. At those levels, further insults to local autonomy by remote utilities, oil companies, banks, and Federal agencies are intolerable. Thus people in Washington sit drawing reactors and coalplexes on maps, but the exercise has increasingly an air of unreality because it is overtaken by political events at the grassroots. The greater the Federal preemption (as in offshore oil leasing), the greater the homeostatic State response. The more the Federal authorities treat centrifugal politics as a public-relations problem, the more likely it becomes that they will not only fail to get their facilities sited, but will also in the process destroy their own legitimacy. To some extent this has already occurred, and I have no doubt that States will soon gain a veto power, at least, over nuclear facilities in their jurisdiction (as current Federal legislation proposes). On this issue, as in other spheres, the traditional linear right-left political spectrum seems to become cyclic as differently grounded distastes for big government merge across gaps of rhetoric. The resurgence of individual, decentralized citizen effort in politics, as in private life and career, seems to me an important political universal in most industrial nations today.

Big Brother does not like losing his grip. Only last year, for example, some Federal officials were speculating that they might have to seek central regulation of domestic solar technologies, lest mass defections from utility grids damage utility cash-flows and the State and municipal budgets dependent on utility tax revenues. Since utilities are perceived as having too much power and utility regulators too little sensitivity already, a surer recipe for grassroots revolt would be hard to imagine. I think perceptions of the value of dependence on utilities are shifting rapidly as the enterprise reaches such a size that it starts to intrude on life in many traditionally "safe" areas, as in Ontario, or as its vulnerability becomes painfully manifest, as in England, or as general political consciousness rises in step with utility bills. The disillusionment and resentment I see in many industrial countries is akin, perhaps, to that of a citizen of a poor country who is realizing that an energy technology predicted to bring him self-reliance, pride, and the development of his village has actually brought him dependence, a cargo-cult mentality, and the enrichment of urban elites. I believe the recent shift of institutional and individual investment away from utilities reflects not only concern with debt structure and interest coverage but also, more fundamentally, with gradual withdrawal of legitimacy by a fickle public that has already done the same to oil majors. I believe further that the grounds of this shift among a previously tolerant, even supportive public are structural, arise essentially from suspicion of centrism, and would not be reversed by nationalization or rechartering that ignored scale.

It is perhaps encouraging, then, that the concept of a soft energy path brings a broad convergence which, even as it coincides with many pre-existing strands of social change, cuts across traditional lines of political conflict. It offers a potential argument for every constituency: civil rights for liberals, States' rights for conservatives, availability of capital for businesspeople, environmental protection for conservationists, old values for the old, new values for the young, exciting technologies for the secular, spiritual rebirth for the religious. As we realize that when we have come to the edge of an abyss, the only progressive move we can make is to step backwards, we begin to see that we can instead turn around and then step forwards, and that the turning around—the transition to a future unlike anything we have ever known—will be supremely interesting, an unprecedented central project for our species.

Faust, having made a bad bargain by not reading the fine print and so brought disaster on the innocent bystanders (Gretchen's family), was eventually redeemed and accepted in heaven because he changed his career, redevoting his talents to bringing soft technologies to the rural villagers. That choice of "the road less travelled by" made all the difference to him; and so it can to us. For underlying the structural differences between the soft and hard paths is a difference of perceptions about mankind and his works. Some people, impressed and fascinated by the glittering achievements of technology, say that if we will only have faith in human ingenuity (theirs) we shall witness the Second Coming of Prometheus (if we have yet recovered from the First), bringing us undreamed-of tyrannies and perils; and that even if we had a clean and unlimited energy source, we would lack the discipline to use it wisely. Such people are really saying, firstly, that energy



is not enough to solve the ancient problems of the human spirit, and secondly, that the technologists who claim they can satisfy the condition that "No acts of God can be permitted" are guilty of *hubris*, the human sin of divine arrogance. In choosing our energy path we have today an opportunity—perhaps our last—to foster in our society a greater humility, one that springs from an appreciation of the essential frailty of the human design.

Amory says it so well. Another one of his major arguments, seconded by Barry Commoner in his *The Poverty of Power* (Knopf, 1976), is that we must now begin to match the thermodynamic quality of end-use energy needed with the renewable energy sources that most readily supply that level of energy quality. Lovins, Commoner and many more Americans daily are realizing that trying to heat one's home, office or industrial plant to 68°F. with electricity generated by burning uranium at 10,000°F. in a nuclear fission reactor is the thermodynamic equivalent of trying to cut butter with a chainsaw. If we, the people, through BPA, supply cheap money to power companies with our government's (i.e. the public's) credit rating, the power plants should belong to us, the public. Despite their thermodynamic silliness, we ought to at least *own* the chainsaws we'll now be paying for on both ends!

You shouldn't have to wait that long, but if you must, the third volume of Amory Lovins' energy trilogy, *Soft Energy Paths: Toward a Durable Peace*, will be available in January 1977 from Friends of the Earth, 529 Commercial Street, San Francisco, CA 94111. If you can't wait, write to Bob Potter, Oak Ridge Associated Universities, P.O. Box 117, Oak Ridge, TN 37830, and ask him how much a copy of Amory's 63-page Oak Ridge address will cost you.

Amory will be in Austin, Texas on December 14-16, at the hearings by the President's Council on Environmental Quality on the ERDA National Energy Plan. RAIN seconds David Brower's nomination of a Nobel Peace Prize for Amory Lovins and hopes anyone who talks with him will buy him a battery for his calculator as a token of their appreciation.

—Lee Johnson

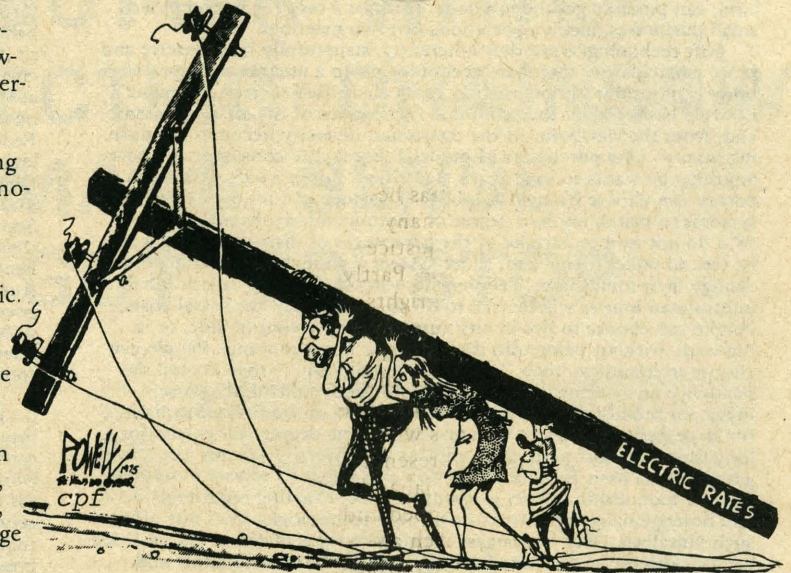

## AGRICULTURE

*Agriculture in the City*, 1976, 74 pp., \$2.75 from:

Community Environmental Council  
109 E. De La Guerra  
Santa Barbara, CA 93101

This book is a cross between a how-to urban gardening manual and a description of the innovative El Mirasol gardening project that CEC had going until the land was sold. Both aspects are interesting and useful, although the image of all that sun in Santa Barbara makes my Oregon garden feel soggy. Now is the time to plan for community gardens if you don't already have one going and this book can give you some exciting ideas for what's possible in the middle of the city: bees, chickens, huge compost piles, classes and enough surplus veggies to generate some extra cash for the project. (LdeM)

*Farming*, \$2.00 from:

Alternative Agriculture Resources Project  
Department of Applied Behavioral Science  
University of California  
Davis, CA 95616

This is the first volume of a comprehensive Sourcebook for a Socially and Ecologically Accountable Agriculture

that has been in preparation for several years by Isao Fujimoto and his cohorts at Davis. Contains good resources on plant diseases, biological control of insects, farm equipment, soils and other aspects of farming. Other sections of the series will be on cooperatives, land, energy and appropriate technology, nutrition and networking. Judging by this first section, the series should be excellent. (TB)

*Country Women: A Handbook for the New Farmer*, by Jeanne Tetrault and Sherry Thomas, 1976, 381 pp., \$6.95 from:

Anchor Press/Doubleday  
245 Park Ave.  
New York, NY 10017

Oooie! This is a beautiful book. It is a good, solid collection of how-to material for homesteading—finding land, building, fencing, planting, harvesting, preserving, raising animals. The photographs leave little doubt that women can do even the heaviest labor when they want to. Yet the book is warm with their experiences and graced with gentle drawings that give the heartening sense of women *nurturing* the land rather than the heroics that others go through to conquer it. It is put together by some of the same women who do a very fine magazine by the same name: *Country Women*, Box 51, Albina, CA 95410. Send a self-addressed, stamped envelope to inquire about price. (LdeM)

*California and Northwest Organic Journal*

P.O. Box 540-H  
Halcyon, CA 93420

\$4.20/year for six issues. Single issue 75¢. This is the journal of the California Organic Growers (membership \$20/yr.)—a group certifying food products "grown without the use of herbicides, poisonous sprays or chemical fertilizers and processed without additives and preservatives." (That's a good definition of "organic" if you've been looking for one.) The "Northwest" in their title is small and feels like an afterthought, but the ads, how-to articles and bits of shared wisdom look to be useful for small California growers. (LdeM)





# PUBLIC INTEREST LAW

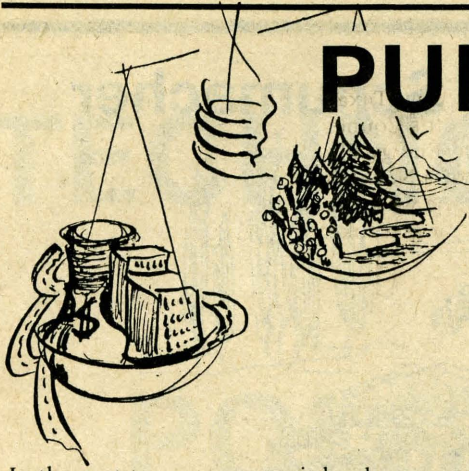

In the past ten years or so, it has become increasingly obvious to many Americans that our system of justice isn't quite as fair as it should be. Partly as an outgrowth of earlier civil rights, civil liberties and legal aid group movements, the new concept of public interest law includes those lawyers and law firms who provide free (or unusually cheap) legal services to folks who have not been able to find representation before. Now the poor, racial and ethnic minorities, the handicapped and children, as well as interests such as environmentalism and consumer affairs, can be heard in court.

For an excellent review of the development of the public interest law movement, descriptions of how and for whom specific groups work, how they are now financed and what their prospects are, see:

*Balancing the Scales of Justice; Financing Public Interest Law in America, 1976* (write for price and availability) to:

**The Council for Public Interest Law**  
1250 Connecticut Ave., N.W.  
Washington, DC 20036

If you feel you could use the services of such a law firm, the Council is the place to write.

Two of the larger public interest law firms handle cases for a number of these previously neglected groups and individuals. They deal with health problems of the poor, occupational health and safety, foreign affairs decision-making, consumer affairs, protection of the environment, access to the media and minority rights.

**Public Advocates, Inc.**  
433 Turk St.  
San Francisco, CA 94101  
415/441-8850

Public Advocates, Inc. has served as general or special counsel for such diverse groups as the National Organization for Women, Consumers Cooperative of Berkeley, Inc., The Officers for Justice and the Childcare Switchboard.

## Center for Law and Social Policy (CLASP)

1751 N St., N.W.  
Washington, DC 20036  
202/872-0670

In 1971 this two-year-old organization formed a division known as the International Project, which focuses on consumer and environmental issues within the foreign affairs decision-making process (e.g. trade regulations and maritime pollution). In 1972, in conjunction with the ACLU and the American Orthopsychiatric Association, they formed a Mental Health Law Project. Their Women's Rights Project came about in 1973, and in 1975 they joined forces with the Media Access Project.

Some other public interest law groups which are listed below usually specialize in serving specific interests.

## The Institute for Public Interest Representation

**Georgetown University Law Center**  
700 New Jersey Ave., N.W.  
Washington, DC 20001  
202/624-8390

In addition to conducting research, students here work closely with various federal and municipal agencies. They petition before the agencies for rule-making, comment on rules they propose, intervene in their adjudicative proceedings, and bring suit against them on behalf of clients who are seeking access to government records under the Freedom of Information Act.

**Women's Law Fund, Inc.**  
620 Keith Building  
1621 Euclid Ave.  
Cleveland, OH 44115  
216/621-3443

The Women's Law Fund supervises law students from the Sex Discrimination and Employment Clinic at the Cleveland State University Law School and, through litigation and education, is working on the elimination of sex discrimination in employment, housing, education and government benefits.

**League of Women Voters Education Fund Litigation Dept.**  
1730 M St., N.W.  
Washington, DC 20036  
202/659-2686

The Department principally handles cases involving local and state leagues in litigation about voting rights, campaign finance, open meetings/open records and equal opportunity. They also sometimes handle non-league cases of "precedent-setting value."

## Legal Action Center of the City of New York

271 Madison Ave.  
New York, NY 10016  
212/679-6502

This group works principally within the criminal justice system, with special emphasis on rehabilitating ex-convicts and drug abusers. They provide legal services for them, educate their prospective employers and initiate major litigation "designed to establish new legal doctrine regarding the employment rights."

**Education Law Center Inc.**  
Suite 800, 605 Broad St.  
Newark, NJ 07102  
201/624-1815

and

2100 Lewis Tower Bldg.  
225 S. 15th St.  
Philadelphia, PA 19102  
215/732-6655

The Education Law Center specializes in issues relating to public elementary and secondary schools in the New Jersey and Philadelphia areas. They are concerned about parental access to pupil records, the adequacy, availability and quality of school facilities, programs and personnel, and sexual and racial discrimination within the public schools. They bring suit when necessary, give legal counsel to "education consumers," and draft and comment on legislation and legally-oriented regulations.

**Center for Law in the Public Interest**  
10203 Santa Monica Blvd., 5th Flr.  
Los Angeles, CA 90067  
213/879-5588

The folks at this center focus their attention on environmental and quality of life issues in the state of California. In addition to bringing "important and precedent-setting" cases to court, they negotiate with the government and private industries and monitor state and federal regulatory agencies to assure that new and existing environmental regulations are properly implemented.

**Oregon Volunteer Lawyers for the Arts at the Northwestern School of Law**  
Lewis and Clark College  
10015 S.W. Terwilliger Blvd.  
Portland, OR 97219  
503/244-1181

The school provides legal service to artists having problems with contracts, taxes, copyrights, obscenity or theft, and sponsors a yearly conference in Law and the Visual Arts.

—Lauri deMoll



(Courtesy E. F. Schumacher and Satish Kumar, editor, *Resurgence*. U.S. subscriptions are \$10 surface mail, \$15 airmail, from *Resurgence*, Pentre Ifan, Felindre, Crymch, Dyfed, Wales, U.K.)

## E. F. Schumacher

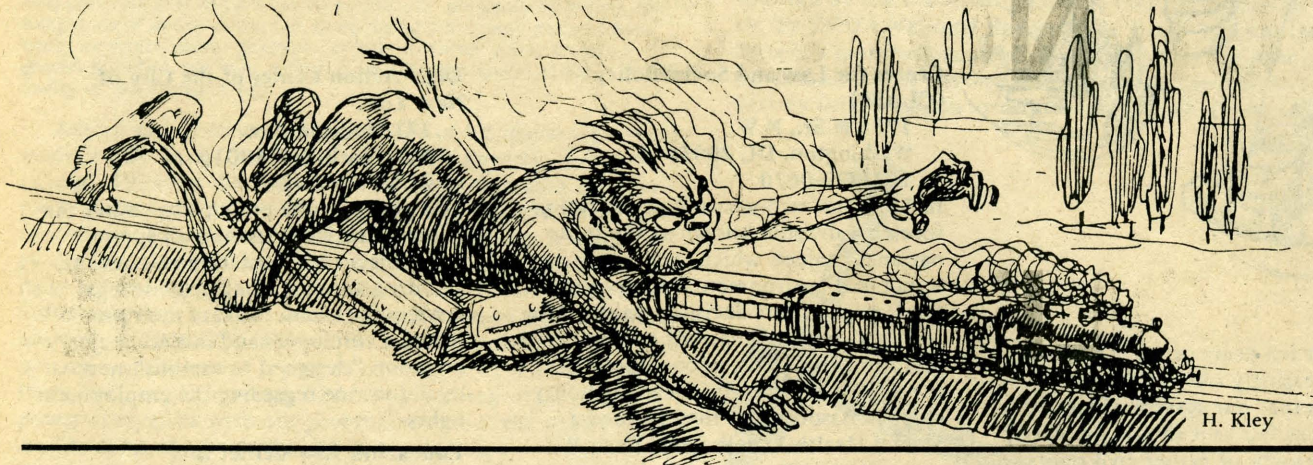

Few people deny that technological change has political consequences; yet equally few people seem to realise that the present 'system,' in the widest sense, is the product of technology and cannot be significantly changed unless technology is changed.

The question may be asked: What is it that has produced modern technology? Various answers can be given. We may go back to the Renaissance, or even further, to the arising of Nominalism, and point to certain changes in Western man's attitude to religion, science, Nature, and society, which then apparently released the intellectual energies for modern technological development. Marx and Engels gave a more direct explanation: the rising power of the bourgeoisie, that is, 'the class of modern capitalist, owners of the means of social production, and employers of wage labour.'

The bourgeoisie, wherever it has got the upper hand, has put an end to all feudal, patriarchal, idyllic relations. It has pitilessly torn asunder the motley feudal ties that bound man to his 'natural superiors,' and has left no other bond between man and man than naked self-interest, than callous 'cash payment'...

It compels all nations, on pain of extinction, to adopt the bourgeois mode of production.

The bourgeoisie has subjected the country to the rule of the towns. It has created enormous cities... has agglomerated population, centralised means of production, and has concentrated property in a few hands.

If the bourgeoisie did all this, what enabled it to do so? The answer cannot be in doubt; the creation of modern technologies. Once a process of technological development has been set in motion it proceeds largely by its own momentum irrespective of the intentions of its originators. It demands an appropriate 'system,' for inappropriate systems spell inefficiency and failure. Whoever created modern technology, for whatever purpose, this technology or, to use the Marxian term, these modes of production, now demand a system that *suits them*, that is appropriate to them.

### Society in crisis

As our modern society is unquestionably in crisis, there must be something that does not fit.

(a) If overall performance is poor despite brilliant technology, maybe the 'system' does not fit.

(b) Or maybe the technology itself does not fit present-day realities, including human nature.

Which of the two is it? This is a very crucial question. The assumption most generally met is that the technology is all right—or can be put right at a moment's notice—but that the 'system' is so faulty it cannot cope:

Modern bourgeois society with its relations of production, of exchange and of property, a society that has conjured up such gigantic means of production and of exchange is like the sorcerer

who is no longer able to control the powers of the nether world whom he has called up by his spells... The conditions of bourgeois society are too narrow to comprise the wealth created by them. And how does the bourgeoisie get over these crises? On the one hand by the enforced destruction of a mass of productive forces; on the other by the conquest of new markets and by the more thorough exploitation of the old ones. That is to say, by paving the way for more extensive and more destructive crises, and by diminishing the means by which crises are prevented." (Marx and Engels: *Manifesto of the Communist Party*, 1848).

The culprit is the Capitalist System, the Profit System, the Market System, or, alternatively, nationalisation, bureaucracy, democracy, planning or the incompetence of the bosses. In short: we have a splendid train but a bad track or a rotten driver or a lot of stupid, unruly passengers.

Maybe all this is quite true, except that we do not have such a splendid train at all. Maybe what is most wrong is that which has been and continues to be the strongest formative force—the technology itself.

If our technology has been created mainly by the capitalist system, is it not probable that it bears the marks of its origin, a technology for the few at the expense of the masses, a technology of exploitation, a technology that is class-oriented, undemocratic, inhuman, and also unecological and non-conservationist?

### Uncritical docility

I never cease to be astonished at the docility with which people—even those who call themselves Socialists or Marxists—accept technology, uncritically, as if technology were a part of Natural Law. As an example of this 'docility' we may take the Prime Minister of Iran who is reported to have said in a recent interview (*To the Point International*, January 12, 1976):

There are many aspects of the West that we particularly wish to avoid in the industrialisation of Iran. We seek the West's technology only, not its ideology. What we wish to avoid is an ideological transplant.

The implicit assumption is that you can have a technological transplant without getting at the same time an ideological transplant; that technology is ideologically neutral; that you can acquire the hardware without the software that lies behind it, has made the hardware possible, and keeps it moving. Is this not a bit like saying: I want to import eggs for hatching, but I don't want chicks from them but mice or kangaroos?

I do not wish to overstate the case; there is nothing absolutely clear-cut in this world, and, no doubt, many different tunes can be played on the same piano, but whatever is played, it will be piano music. I agree with the general meaning of Marx's rhetorical question: "Does it require deep intuition to comprehend that man's ideas, views, and conceptions—in a



# TECHNOLOGY AND POLITICAL CHANGE

word, man's consciousness—changes (he does not say: is totally determined) with every change in the conditions of his material existence, in his social relations and in his social life?"

It is a great error to overlook or to underestimate the effects of the 'modes of production' upon people's *lives*, not just their 'standard of living':

- how they produce; what they produce;
- where they work; where they live; whom they meet;
- how they relax or 'recreate' themselves; what they eat, breathe and see;
- and therefore what they think, their freedom or their dependence.

Adam Smith was under no illusion about the effects of the 'mode of production' on the worker:

The understandings of the greater part of men are necessarily formed by their ordinary employments. The man whose whole life is spent in performing a few simple operations . . . has no occasion to exert his understanding. . . . He naturally loses, therefore, the habit of such exertion and generally becomes as stupid and ignorant as it is possible for a human creature to become. . . . But in every improved and civilized society this is the state into which the labouring poor, that is, the great body of the people, must necessarily fall, unless government takes some pains to prevent it."

Marx, who quotes Adam Smith, adds the comment that

Some crippling of body and mind is inseparable even from division of labour in society as a whole. Since, however, manufacture carries this . . . much further and also, by its peculiar division, attacks the individual at the very roots of his life, it is the first to afford the materials for, and give start to, industrial pathology.

And he quotes his contemporary, D. Urquhart, who says: "the subdivision of labour is the assassination of a people."

## Better society needs a different technology

People still say: it is not the technology; it is the 'system.' Maybe a particular 'system' gave birth to this technology; but now it stares us in the face that the system we have is the product, the inevitable product, of the technology. As I compare the societies which appear to have different 'systems,' the evidence seems to be overwhelming that where they employ the same technology they act very much the same and become more alike every day. Mindless work in office or factory is equally mindless under any system.

I suggest therefore that those who want to promote a *better* society, achieve a *better* system, must not confine their activities to attempts to change the 'superstructure'—laws, rules, agreements, taxes, welfare, education, health services, etc. The expenditure incurred in trying to buy a better society can be like pouring money into a bottomless pit. If there is no change in the base—which is technology—there is unlikely to be any *real* change in the superstructure.

People say to me: before you can make headway with your 'Intermediate Technology' you must first change the system, do away with capitalism and the profit motive, dissolve the multinationals, abolish all bureaucracies, and reform education. All I can reply is: I know of no better way of changing the 'system' than by putting into the world a *new type* of technology—technologies by which small people can make themselves productive and relatively independent.

During the eighteenth and nineteenth centuries technology just grew like Topsy. Increasingly, however, it became the outgrowth of Science. Today, its primary derivation is from Science; in fact, it appears that Science is today mainly valued for its technological fruits.

Starting, then, with Science, the question may be raised: what determines the course of Science? There is always more that *could* be studied than *can* be studied; so there is need for choice, and how is it made?

By the interests of scientists? Yes, unquestionably.

By the interests of big business and government? Surely yes.

By the interests of 'the people'? On the whole, no!

The people have fairly simple requirements to meet for which hardly any additional science is needed. (It could be that an entirely different *kind* of science would really benefit the people; but that is another matter.)

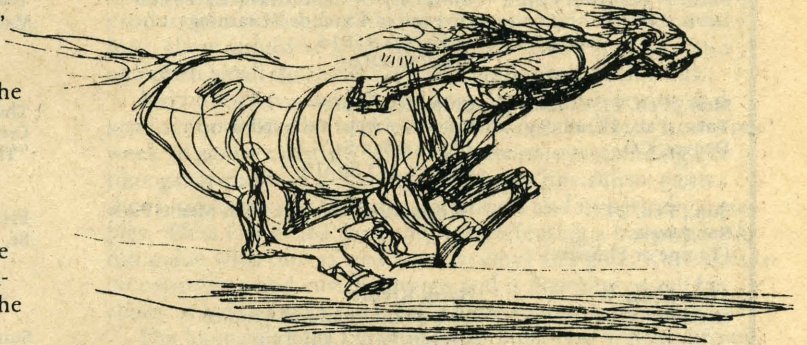

## Cautionary example of USA

Moving from Science to Technology, there is again far more that *could* be done than *can* be done. The choice is endless. Who decides or what decides? Scientific findings can be used for, 'incarnated in,' countless different 'shapes' of technology, but new technologies are developed only when people of power and wealth back the development. In other words, the new technologies will be in the image of the system that brings them forth, *and they will reinforce the system*. If the system is ruled by giant enterprises—whether privately or publicly owned—the new technologies will tend to be 'gigantic'



in one way or another, designed for 'massive breakthroughs,' at massive cost, demanding extreme specialisation, promising a massive impact—no matter how violent—"we shall know how to cope with the consequences." The slogan is: "a breakthrough a day keeps the crisis at bay." We hear of 'white hot technological revolution,' the Nuclear Age, the Agent of Automation, the Space Age, fantastic feats of engineering, supersonic triumphs, all that; but many of the most basic needs of great masses of people, such as housing, cannot be taken care of.

The most telling example, of course, is the most advanced society of the modern world, the United States. Average income per head is over twice that of Britain or Western Europe, and yet there is more degrading poverty in the States than you can ever see in Europe; 5.6 percent of the world population using something like 35 percent of the world's output of raw materials—and not a happy place: great wealth in some places but utter misery, degradation, hopelessness, strife, criminality, escapism, sickness of body and mind almost everywhere; it is hard to get away from it. How is it possible—in a country that has more resources, more science and technology than anybody ever had in human history? People are questioning everything, every part of the superstructure—big business, big government, big academia; and very gradually, hesitantly, at long last they are beginning to question the basis of it all—technology.

Technology Assessment Groups have sprung up in various places; they 'assess' technological developments mainly in the light of three questions:

"What does it do in terms of resource usage?"

"What does it do to the Environment?"

"What is its socio-political relevance?"

Concorde did not fare well under their scrutiny. They concluded that it was wasteful of scarce resources, environmentally burdensome and even dangerous, and socio-politically irrelevant. It may none the less be described as a marvelous achievement of Anglo-French engineering.

We'll follow through with a few of the structural effects of modern technology in the next issue (to be continued in the January 1977 RAIN).



*E. F. Schumacher is coming to town! Below is a list of places where he will speak or be part of a regional gathering. Each of the events here will be open to the public. Call or write the contact people listed beside each date for information, exact time, price, etc. Also contact them if you might be willing to*

- Thurs., Feb. 10, 2-8 pm Rick Cohen  
Albany, NY Institute for Man & Science  
Rensselaerville, NY 12147  
518/797-3783
- Fri., Feb. 11 William Irwin Thompson  
Evening Speech Lindsfarne Assn.  
City Center, NYC 49 West 20th  
New York, NY 10011
- Thurs. & Fri., Feb. 17, 18 Yvonne Hunter  
Small Is Beautiful Conf. University of Calif., Davis Extension  
Davis, CA Division of Extended Learning  
Davis, CA 95616  
916/752-2820
- Mon., Feb. 21, evening Chip Presendofer  
Tues., Feb. 22, all day Colorado App. Tech. Network  
Denver, CO 1411 Ogden St.  
Denver, CO 80218
- Sun., Feb. 27 Information—contact IT in Menlo Park  
Southwest (Tempe or Phoenix)
- Thurs., Mar. 3 Harry Kreisler  
Berkeley, CA Inst. of International Studies  
University of California  
Berkeley, CA 94720  
415/642-1106
- Sat., Mar. 5 Rev. David Cooling  
San Francisco Episcopal Diocese of California  
"Urban Poor and Grace Cathedral  
Minorities in Relation 1051 Taylor St.  
to AT" San Francisco, CA 94108  
415/776-6611
- Sun., Mar. 6 Sermon at Grace Cathedral  
San Francisco

*co-sponsor and/or help organize the event in your area. Special thanks to Intermediate Technology/USA for organizing this tour. For questions about the trip as a whole or to get on a list for 1978, contact them: IT/USA, 556 Santa Cruz Ave., Menlo Park, CA 94025, 415/328-1730.*

- Sun., Mar. 6, afternoon Dorothy A. Huges  
San Rafael, CA Marin Mental Health Assn.  
Theme: Suburban/ 1368 Lincoln Ave.  
middle class, Ecotopia, San Rafael, CA 94901  
homesteading, etc. 415/456-7693
- Mon., Mar. 7 Dr. M. Evelyn Jonescu  
Regina, Saskatchewan Canadian Plains Research Center  
University of Regina  
Regina, Saskatchewan
- Tues., Mar. 8 Bernd Foerster  
Manhattan, KS College of Architecture and Design  
Kansas State University  
Manhattan, KS 66506  
913/532-5951
- Thurs., Mar. 10 Philip Heckman  
Crete, NB Doane College  
"The Prairie Project" Crete, NB 68333  
402/826-2161
- Fri-Sat., Mar. 11-12 Lance Holthusen  
St. Paul, MN Science Museum of Minnesota  
30 East 10th  
St. Paul, MN 55101  
612/222-6303
- Sun.-Mon., Mar. 13-14 Diane Catman  
Ann Arbor, MI UAC Office  
University of Michigan  
Ann Arbor, MI 48104
- Sat., Mar. 19 Bethe Hagens & Jim Laukes  
Park Forest South, IL Acorn  
Governor's State University  
Park Forest South, IL 60466  
312/534-5000
- Mon., Mar. 21 Possible gathering of AT people with  
Washington, DC senators and representatives, etc.  
Interested? Call IT



# ALL SEWN UP

Somewhere in the woods around Baldwin, Wisconsin, there is a small, one-room schoolhouse in which the Fabric Appliance Company does business and its creator, a friend of ours by the name of Kurt Buetow, homesteads. Kurt makes chairs. Wonderfully comfortable, hanging chairs of canvas carefully cut to fit the body. The fact that Kurt's chair won first prize in the first annual Canvas Furniture Design Competition held in Tokyo in 1974 has helped business quite a bit, but then that has its bad points too.

"When I get away from the whole deal and pretend that I'm a politician or an economist, then I think it's wonderful to produce a 'product.' But mostly I feel a void when the basis for my contact with people is money." Far from wanting to protect or patent the design of his now famous chairs, Kurt would like to see it "spread around," but he hasn't yet stumbled onto the proper vehicle. We were trying to figure out a way of setting up a technologically appropriate method of producing the chair, perhaps modeled after the system of the Nomadic Tipi Makers on the Oregon coast. They contract



out tipi sewing to local farmers' wives who use the orders as collateral for buying their own industrial sewing machines; they can then apply their equipment and skills to other local productions. Instead of having to finance and operate a factory, there would be a network of self-reliance, skilled and equipped small businesses which could serve local needs.

Kurt does have some help these days on the sewing and production work, on which he spends ten to fifteen hours per week to gain a cashflow. Otherwise he enjoys spending his time gardening and designing new things like shirts, pants, shoes, raincoats, kites, water containers and hyperbolic canopies. When last heard from, he was perfecting a hanging bathtub made with canvas treated with vinyl and glue. Kurt likes to do consulting and custom design and is planning to sell his chairs in kit and plan form for people to assemble at home.

The hanging chairs come in royal blue, red, yellow, brown, black, kelly or forest green, turquoise and white, and sell for \$42 retail, \$30 when ordered directly from the company or from his West Coast distributor, Huey Johnson, or \$24 without the dowels. He also makes a tête-à-tête (two facing chairs) for \$50, and a four-person set for \$120. They are attractive, durable and extremely comfortable. If you are interested in sewing or selling the chairs, or just in ordering one or two, contact: Huey Johnson, Webworks, 35 Elm, Mill Valley, CA 94941, or The Fabric Appliance Co., Rt. 1, Box 150 A, Baldwin, WI 54002.

—Lauri deMoll





*The Methods of Construction of Celtic Art*, George Bain, Dover Art Series, \$4.00

Beautiful interlacing Celtic ornaments, spirals, initials, human and animal designs. Examples, illustrations and how to construct.

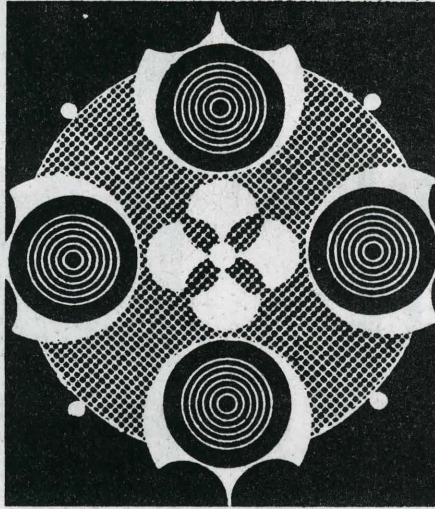

*Geometric Design and Ornament*, Edmund Gillon, Jr., Dover Pictorial Archives, \$2.50

374 unusual designs of Russian origin—striking geometric interplays, interlocking circles—mostly about 3" in size.



*The Underground Sketchbook of Jan Faust*, Dover Pictorial Archives, \$1.50

101 bizarre half-page sketches (we love them!) of fireplugs with built-in urinals, ecologists with trees for hair, coke bottles sucking people down soda straws and other figments of modern civilization.

# GRAPHICS

One of the fun things in putting together a magazine or a poster is finding good graphics to go with the information and then putting them together in a way that looks and feels good.

**CHOOSING GRAPHICS** depends on several factors—your budget, the amount of time you have to mess with finding graphics, what sources you have easily available, and what you want to use the graphics for. Graphics can be used to draw people's attention to the poster, article or magazine, to

separate different things on a page, give relief from words, help you remember where you are reading, convey the spirit of an article, illustrate an idea, show something that exists, or carry a major part of the message you are trying to convey. If you're trying to convince people that something is possible, a photograph of the real thing is a hundred times as convincing as a sketch of the same thing. Yet often a sketch or cartoon can more dramatically and clearly convey ideas, feelings, or conceptual images. And frequently it's not worth the time necessary to find and process the "perfect" image.

*Japanese Design Motifs*, Matsuya Co. Co., Dover Pictorial Archives, \$4.95.

Over 4000 beautiful 1-1/2" square stylized designs—animals, flowers, swords, fans, geometries.

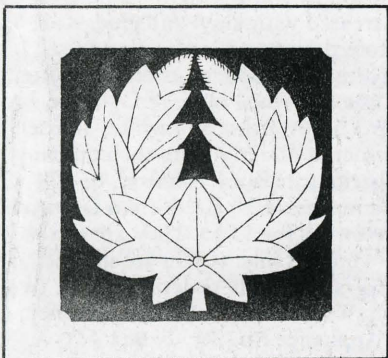

*Picture Sourcebook for Collage and Decoupage*, Edmond Gillon, Jr., Dover Pictorial Archives, \$3.95

If you need odd, weird things, go here. 317 often crude but curious scenes, figures, images.

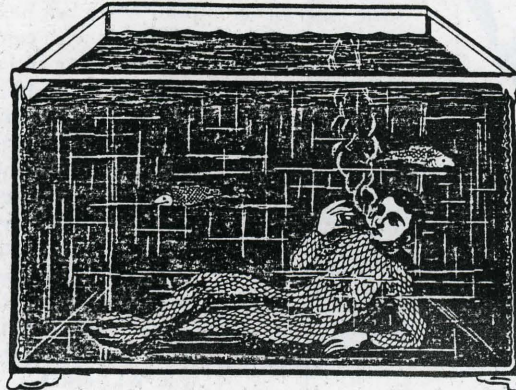

*Chinese Cut-Paper Designs*, Theodore Menten, Dover Pictorial Archives, \$3.00

269 illustrations of mixed quality—some cloying, some delightful—mostly fairly large, but fine papercuts of horses, warriors, tigers, children and pandas.





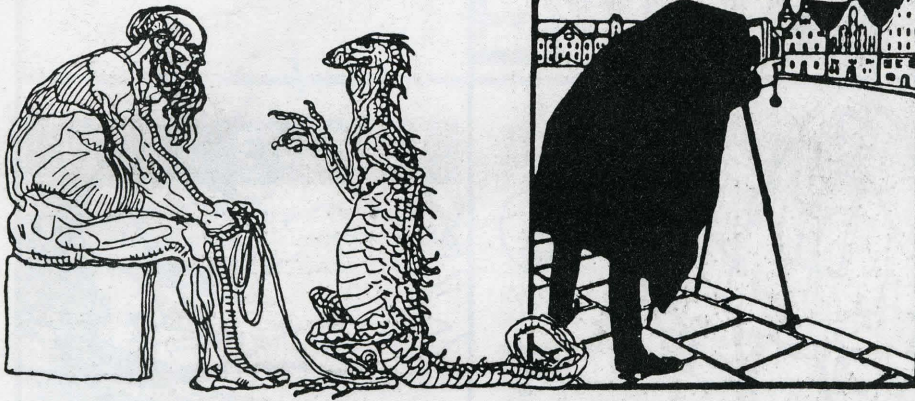

*The Drawings of Heinrich Kley, Dover Art Series, \$2.00*  
200 exquisite full-page drawings and thumbnail sketches full of Kley's insanely sensitive elephants, women and bizarre events.

*Graphic Trade Symbols by German Designers, F. H. Ehmcke, Dover Pictorial Archives, \$2.50*  
350 powerful, striking symbols of trades, amusements, products—2" to 3" in size. Really nice.

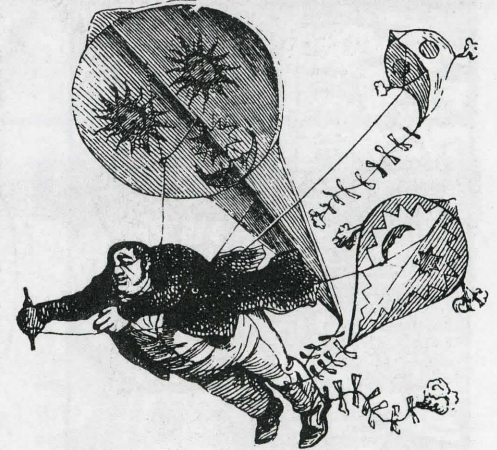

*Bizarries and Fantasies of Grandville, Dover Art Series, \$4.00*  
One of our favorites. 266 mostly half-page tableaux filled with Grandville's amazing creatures—dancing steam pipes, garden vegetables voting, an imaginary volvox epidemic, a battle of playing cards. Delightful images.

**TITLES AND EMPTY SPACE** around the text are probably the simplest source for graphic effect. Press-on letters can be used to make titles in a wide range of sizes and type styles. They're available at most art supply stores and cost \$3 to \$4.50 per sheet. The same companies that make the press-on letters also make sheets of arrows, people, automobiles, lines, symbols—most anything you can imagine. In a pinch we've even cut up their catalogs to use the graphics!

**HEADLINERS** are another source of titles that is faster, somewhat more professional looking and sometimes cheaper than press letters. Go to a newspaper or typesetting service that has photographic typesetters (Compugraphic, Headliner, Photo Typositor), which can make titles, headlines or large type excerpts of almost any size. The number of type styles available at any one typesetter is usually less than what you can get in press-on letters.

**"COMMUNITY PRESS FEATURES,"** a monthly collection of camera-ready cartoons, graphics and articles put out by

Urban Planning Aid, 639 Massachusetts Ave., Cambridge, MA 02139, can be clipped and used in community and other publications if you need a source of reproducible graphics. Generally focussed on social change, the graphics are culled from many sources and styles. Free to community papers, \$10/year to individuals and non-profit organizations who can afford it, and \$30/year to libraries and profit-making institutions. Probably the best source of graphics—to say what you really want to say—is yourself and your friends. Sketches, cartoons, photographs, if you have time, energy and skill to do them, are both fun and useful.

If you want to get hold of a professional cartoonist you know about to see if he would be interested in doing something you want done, and to find out prices, contact:

**Association of American Editorial Cartoonists**  
Evening Journal News  
631 Orange Street  
Wilmington, DE 19803

*1800 Woodcuts by Thomas Bewick and His School, Dover Pictorial Archives, \$5.00*  
247 pages of finely-detailed engravings of birds, animals, fish, rustic scenes, trade symbols, small vignettes. One of the best quality, most varied sources we've found.

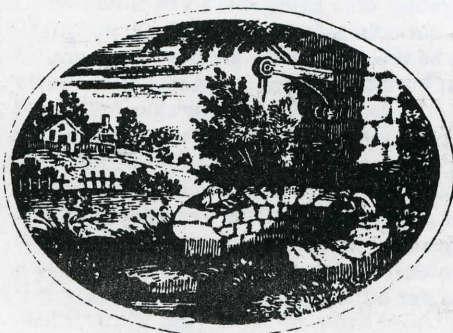

*Alphabets and Ornaments, Ernst Lehner, Dover Pictorial Archives, \$4.50*  
Titles are misleading—this has buried in it some exquisite Balinese shadow puppets, lace designs, fleurons and borders, scripts and scrolls, and beautiful ornamented alphabets.



*Decorative Art of the Southwestern Indians, Dorothy Sides, Dover Pictorial Archives, \$1.50*  
295 strong and clearly reproducible designs from Pueblo pottery, Hopi kachinas and beadwork from many tribes. Nice things. Varied sizes, shapes.







*Symbols, Signs and Signets*, Ernst Lehner, Dover Pictorial Archives, \$3.50

More than 1300 graphics—mostly one-column size. Japanese crests, watermarks, monsters and imaginary figures, church symbols, astrology, gods and deities.

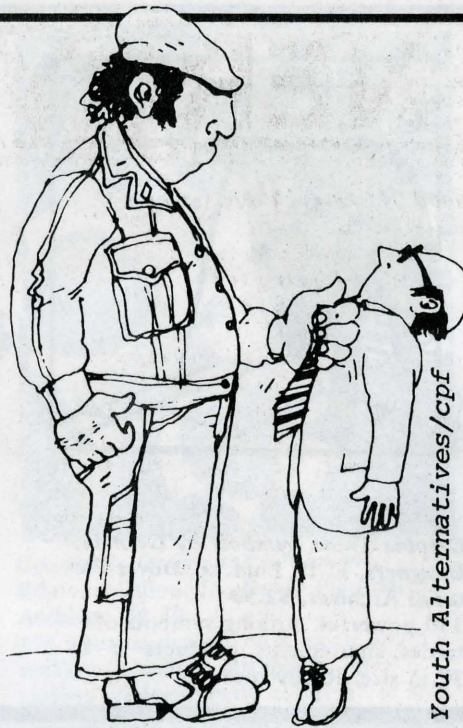

*Youth Alternatives/cpf*

Community Press Features



*Drawings of Rembrandt, Vol. 1*, Dover Art Series, \$6.00

Excellent, of course—300 portraits, landscapes, figure studies of all sizes. Generally on grey background, but many should reproduce well.

**Cartoonists Guild**

156 W. 72nd Street  
New York, NY 10023

**National Cartoonists Society**

9 Ebony Court  
Brooklyn, NY 11229

**THE PICTORIAL ARCHIVES SERIES** of books put out by Dover Publications, 180 Varick St., New York, NY 10014, is probably our favorite standby graphic source. This unique series of more than 90 books has been specifically designed for the artists, designers and other persons who use pictorial material in their work. When you buy a book in the series, you buy full reproduction rights to material in the book as long as you don't reprint the whole volume. Most of the series are collections of old things which aren't copyrighted anyway, but they have several books of new sketches and photographs which are interesting. Their catalog suggests that much of the material in their artbook series is also suitable for reproduction! It's sometimes hard to tell from the titles whether you'll like what's in the books—it's best to look through some in a bookstore.

**BEGGED, BORROWED OR STOLEN GRAPHICS** from books, magazines or newspapers is the next step up. If you're doing this for your own use, it's probably okay, but if you're printing something publicly and especially if for profit, you're likely to run into problems with copyrights on the materials. This is particularly a problem with cartoons and photographs, as that's how those people earn their livings and they generally don't like unauthorized use of their material. It's worth a try, though, to ask for permission to use something if you really like it—if you're non-profit the charge is often \$10 to \$25 for permission to use once.

**OLD NON-COPYRIGHTED BOOKS** are another good source of photographs, etchings, woodcuts and other graphics. Check in the front of the book to see if it is copyrighted. Old books, and many academic reports and journals, are not copyrighted.

Interesting photographs can often be found in photographic archives in libraries, historical societies, museums and maybe your grandmother's attic. You can also take a gamble on books you're pretty sure are "bluffing" their copyright. Obviously the drawings in a book of Rembrandt sketches aren't copyrighted—the copyright is often only on the introduction/text and to prevent reproduction of the book as a whole.

**GETTING GRAPHICS READY FOR PRINTING** may involve several different processes. If you clip the graphic out and it's the right size, just attach it to your layout sheets. If it's in a book, we've found that normal xeroxing usually isn't good enough quality for reprinting, but copies made on a Royal copier (and probably other brands designed for reproduction of photographs) are usually okay. Line drawings can be shrunk on the Xerox 7000 and 9200 machines, though the 9200 won't take books. Reduction of other graphics costs more—about \$3.00 to have a reduced or enlarged print (PMT) made the size you need, already screened (if necessary) for printing. Some Xerox centers have acetate sheets covered with fine white dots or lines that you can place over a drawing or photo to Xerox—gives a coarse but sometimes interesting ready-to-print copy.

It is sad, but perhaps not, that too often we feel dependent upon sources like these rather than being able to let flow our own expressiveness, our own unique sense of what is right here and now that can't be touched by the greatest art of any other time or place—that burning and unquenchable consciousness of now that must pour forth to meld all our changes into a new sense of being. We all need to learn to let that flow—both in ourselves and as a society. Yet it's not really ready today, and for some it will flow better as words than as pictures; as sounds or as movement; as bread, or as smiles or bricks. And always there are so many things we want to do that certain ones have to wait their turns—replaced for now by ways that allow us to put our energy other places, where it's more needed.

—Tom Bender



# ENERGY

## WOOD ENERGY

"An Analysis of Woodstove Performance," Jay Shelton, *Country Journal*, Oct. 1976, pp. 47-50, \$1/issue, \$10/yr. from:

139 Main Street  
Brattleboro, VT 05301

A long-awaited and refreshingly candid comparative analysis of energy efficiency of different kinds of wood heaters. Should fuel the fire of efficiency studies for quite a while. Stoves studied ranged from Franklin fireplaces to oil barrel stoves to air-tight heaters and Scandinavian imports. Efficiencies of stoves tested ranged from 40 to 65 percent. Almost all stoves tested appeared similar in efficiency, with all displaying a wide range of performance depending on how they were operated. A number of factors significant in performance are discussed, including size of pieces of wood burned, heat transfer from stovepipes, low vs. high burning rates, ease of operation and fuel capacity. A number of useful pointers for choosing wood heaters are given.

*Woodburners Encyclopedia*, by Raymond Montgomery and Jay Shelton is to be published soon at \$5.95 by:  
Vermont Crossroads Press  
Waitsfield, VT 05673



*The SEVCA Stove*  
Southeastern Vermont Community  
Action  
9 Westminster Street  
Bellows Falls, VT 05101

This is the stove that got top rating in Jay Shelton's wood stove energy efficiency tests. It's not a slick commercial model but produced by a local anti-poverty agency for low-income clients. It sells for \$105 to people meeting OEO poverty guidelines (that's most of us!) or \$235 to anyone else. Made out of discarded propane tanks. Hmmm! . . . if everyone who uses bottled gas cut up their tanks. . . . A good example of top quality work being done by small local groups.

*Wood 'N Energy*, \$5/yr. (at least 4 issues) from:

Society for the Protection of New  
Hampshire Forests  
5 South State Street  
Concord, NH 03301

Keep your eye on New England in energy matters—they've raced ahead of the rest of the country in energy conservation and conversion to renewable energy sources, pushed by skyrocketing energy costs and restricted fuel imports. *Wood 'N Energy* covers the real cutting edge of developments in use of wood energy—from the long range prospects for wood as an energy source in New England to the immediate "how-to" details of stoves and cordwood. It specifically covers information on efficient home heating, woodlot management, development of wood chip burners, generation of electricity from wood and production of methanol and other wood products.



"Getting Fire—A Field Guide to the Stoves" in *Maine Times*, October 22, 1976, 30¢ from:

*Maine Times*  
Topsham, ME 04086

A good guide to how different kinds of wood heaters work and feedback from users on specific problems/features of different stoves. Compiled with the help of Albie Barden of Maine Wood Heat Co., RFD 1, Box 38, Norridgewock, ME 04957, who is preparing a more extensive guide to wood-burning stoves and heaters.

*Wood Burning Quarterly*, \$4.95/yr. from:

8009 34th Avenue So.  
Minneapolis, MN 55420

Similar in format to *Organic Gardening and Farming* but oriented to people who heat with wood. Short consumer articles on topics such as energy-efficient fireplaces and avoiding chimney fires and an extensive product access for wood stoves, heaters and accessories. Articles don't yet seem to be abreast of the most recent developments in a rapidly changing field, but we've only seen their first issue. Should provide a useful service as it gets shaken down.

—Tom Bender

## BIOCONVERSION

"An Economic Analysis of Fuel Gas Production from Solid Waste," by R. G. Kispert, S. E. Sawdek and D. L. Wise, in *Resource Recovery and Conservation*, Vol. 1, No. 1, pp. 95-109, 1975.

Summary of a study done for NSF-RANN on an anaerobic system for converting 1000 tons/day of urban solid waste to methane gas. The concept, similar to the older L.A. plant mentioned earlier, is being demonstrated by ERDA at a \$2 million plant now under construction in Pompano Beach, Florida. Contact Don Walters, ERDA Fuels from Biomass Program, Washington, DC for progress reports.

Also:

"An Evaluation of Methane Production from Solid Waste," by the same authors, in the same journal as above, vol. 3, no. 3, pp. 245-255, 1976.

A technology assessment of where methane conversion of solid waste would be most economically attractive in the U.S. A map suggesting 18 specific sites, mostly in the northeastern U.S., is included.

*Resource Recovery* is \$43.40/year. For subscription, reprint and single-copy price, write:

Dr. Harvey Alter, editor  
Resource Recovery and Conservation  
National Center for Resource  
Recovery, Inc.  
1211 Connecticut Ave., N.W.  
Washington, D.C. 20036

*The Anaerobic Digestion of Livestock Wastes to Produce Methane, 1946-June 1975: A Bibliography with Abstracts*, Gregg Shadduck and James A. Moore, 1975, \$2 from:

J. A. Moore  
Ag. Engineering Dept.  
University of Minnesota  
St. Paul, MN 55108

Most of the current interest in methane is focused on manure as a prime resource. This is the best annotated bibliography on the subject, tracing the history of the process from its beginning, through many foreign experiences (Germany, India, France), laboratory results, and current projects. Smaller sections focus on digestion of farm-generated cellulosic materials (straw, cornstalks, etc.) and the fertilizing qualities of digester effluent.



**Los Angeles Sewage Treatment Plant, for info write:**

**Hyperion Treatment Plant  
12000 Vista del Mar  
Playa Del Rey, CA 90291**

Built in 1942, 18 digesters each 100' in diameter produce a total of 5 million cu. ft. of methane gas daily. 2.5 Mcf runs the plant, the other 2.5 Mcf runs gas turbines which produce electricity at the public utility located next to it. Its fertilizer plant, at which dried digester sludge was bagged and sold to nearby farms, is no longer operational although all equipment is intact. A free pamphlet is available.

**Bio-Gas Plant: Generating Methane from Organic Waste, 70 pp., 1973, \$5 plus overseas postage from:**

**Gobar Gas Research Station  
Ajitmal  
Etawah (U.P.)  
INDIA**

Ram Bux Singh and his associates document plans for above- and below-ground, heated and unheated, single- and dual-stage digesters. Performance data on these options is not presented.

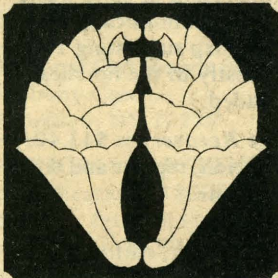

**"Fuel Gas Production from Solid Waste," by D. L. Wise, et. al., in *Bio-Technology and Bio-Engineering Journal*, Symposium No. 5, pp. 285-301, 1975, \$75/yr. from:**

**Elmer L. Gadden, Jr., Editor  
Biotechnology and Bioengineering  
Interscience Publishers  
Div. of John Wiley & Sons  
605 3rd Ave.  
New York, NY 10016**

A survey of who is doing what, where with solid methane-to-methane on the municipal level, in another journal which covers the bioconversion field.

**Study of Current and Proposed Practices in Animal Waste Management, by Whetstone, Parker and Wells, Environmental Protection Agency Report No. 430/9-74-003, January 1974 from:**

**Environmental Protection Agency  
Washington, DC 20460**

1162 publications are abstracted which deal with all aspects of animal waste utilization and/or disposal. About 30

deal directly with methane. Other subjects include algae culturing, composting, conventional sewage treatment, fish culture, lagoons, pathogens and refeeding of manure.



**"Production and Use of Methane from Animal Wastes in Taiwan," by Chung Po, in *International Biomass Energy Proceedings* (see ACCESS section), or write:**

**Dept. of Animal Science  
National Taiwan University  
Taipei, Taiwan**

Chung Po has helped build over 7500 digesters in Taiwan with 3000 gal. capacity and 3 digestion chambers with floating covers, each costing about \$150. Growing algae on the effluent is also explained. —Lee Johnson

## SOLAR ENERGY

**"Designing the Solar-Tempered Home," by Eugene Eccli, in *Low-Cost Energy Efficient Shelter*, pp. 257-287, 1976, \$10.95 from:**

**Rodale Press  
Emmaus, PA 18049**

Includes designs for adjustable solar shade overhangs, solar window construction, moving carpeting, interior masonry walls for thermal mass, including modifications to existing homes.

***Solar Heating Guide*, by Norman B. Saunders, 1976, 16 pp., 50¢ from:**

**Experimental Manor  
Sunshine Circle, 15 Ellis Rd.  
Weston, MA 02193**

Item 1A-75209. An excellent, conversationally-written introduction, based on the author's experience and experiments, including the design of his now 14-year-old direct solar home.

***Solar-Heated Buildings: A Brief Survey*, by William A. Shurcliff, \$9 if check enclosed; \$11 otherwise (add \$1 for first class shipment), from:**

**William A. Shurcliff  
19 Appleton St.  
Cambridge, MA 02138**

Now in its 12th edition, updated about every 6 months, this comprehensive survey of indirect and direct solar applications includes descriptions of 17 such direct-solar buildings as St. George's

School (England), the Odeillo Houses (France), Pointe Bleue (Canada), Lawrence (Australia), Kruschke (U.S.), Terry (U.S.), Wright (U.S.), Mudd (U.S.), Dasburg (U.S.), Baer (U.S.), Kelbaugh (U.S.), Tyrrell (U.S.), Croft (U.S.), Saunders (U.S.), Lasar (U.S.), Aspen (U.S.), Hay (U.S.) and Cleveland (U.S.).

***Drum Wall Plans*, by Steve Baer, \$5 from:**

**Zomeworks  
P.O. Box 712  
Albuquerque, NM 87103**

How to install and operate a water-mass south wall. Includes materials list and instructions. Ask for product-publication price list.

**"Beadwall" by David Harrison in *Solar Energy*, vol. 17, no. 5, Nov. 1975.**

Description of normal and possible system configurations, BTU energy and dollar cost savings relative to single- and double-glazing and overall economics of blowing bean-bag polystyrene beads between two sheets of glass to insulate at night. A Zomeworks product (see "Drumwall Plans" in How-To section for address).

***Sunworld*, quarterly, \$12/year, \$3.50 single copy to non-members of the International Solar Energy Society from:**

**SUNWORLD-ISES  
320 Vassar Ave.  
Berkeley, CA 94708**

First July '76 issue contained Harold SKYTHERM Hay's article on ancient and modern direct solar technology. Watch for increasing coverage of direct solar design and engineering. Free to ISES members.

**and  
*Sunpaper: Newsletter & Journal of the N.M. Solar Energy Assoc.*, \$10/year**

**P.O. Box 2004  
Santa Fe, NM 87501**

These are the two periodicals to watch for best and most up-to-date direct-solar coverage. As for *Sunpaper*, well, most of America's direct-solar pioneers and experts live and work in New Mexico and belong to NMSEA.

***Solar Engineering Magazine*, free to qualifying solar professionals, \$10/yr. for 12 issues to all others, from:**

**Solar Engineering Magazine  
8435 N. Stemmons Freeway,  
Suite 880  
Dallas, TX 75247**

Although indirect (active) solar systems are presently emphasized, this is the best place to look for the few direct solar components now on the market, since it is the only solar mag with reader service cards for easy access to product information. —Lee Johnson



## WIND ENERGY

*The Generation of Electricity by Wind Power*, by E. W. Golding, 1976, \$19.95 (hardbound) from:

Halsted Press  
John Wiley & Sons, Inc.  
605 Third Ave.  
New York, NY 10016

or \$9 paperback (surface mail) from:  
Conservation Tools & Technology  
143 Maple Rd.  
Surbiton, Surrey, England KT6 4BH

Among the best references on wind-power, with extensive treatment of the history and range of wind machine designs, wind characteristics, wind distribution and large-scale installations.

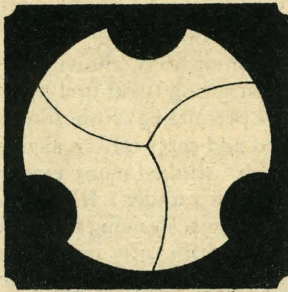

*Wind Machines* (NSF-RA-N-75-051), by Frank R. Eldridge, 1975, MITRE Corp., McLean, VA, 77 pp., Stock No. 938-000-00272-4, \$2.25 from:

Government Printing Office  
Washington, DC 20402

Although little attention is given to small wind generators, the focus being on the past, present and future of large wind-turbines, much information valuable for small-scale applications is presented in a concise, informative, visually superb treatment with excellent photos, graphics and layout. Up-to-date manufacturer-distributor list.

*Windworks Poster*, \$3 from:

Windworks  
Box 329, Rt. 3  
Mukwonago, WI 53149

Beautiful four-color poster with a historical-technical survey of 17 wind machines on the front and an introduction to small-scale wind energy on the back, with expert commentary, references on commercial and do-it-yourself windpower.

*The Gemini Synchronous Inverter Papers*, \$2 postpaid from Windworks for all three:

1. "Synchronous Inversion: Concept and Application," by Hans Meyer, 12 pp., 1976, 50¢;
2. "Synchronous Inversion for Wind-power Utilization," by Alan Wilkerson, 12 pp., 1975, 50¢; and

3. "Synchronous Inversion: Technology for Utilization of Waste Energy," by Alan Wilkerson, 25 pp., 1976, \$1.00.

A free pamphlet on the Gemini, which allows any DC power source to put AC power back into electrical grid and use the existing grid rather than expensive storage batteries, is also available. See also the backside of the Windworks poster above.

**Wind Measurement Equipment:**

1. Dwyer Instruments, Inc.  
P.O. Box 373  
Michigan City, IN 46360
2. Helion  
Box 4301  
Sylmar, CA 91342
3. Natural Power, Inc.  
Box 167-B4  
New Boxton, NH 03070
4. Sencenbaugh Wind Electric  
P.O. Box 11174  
Palo Alto, CA 94306

The above offer the necessary wind-monitoring equipment at low cost.

**Do-It-Yourself Plans:**

1. Helion — 12' and 16' (2-5kw) wind generator plans, \$10
2. Sencenbaugh — 10' diameter wind generator
3. Windworks — 25' diameter sailing windmill plans, \$25, 12' diameter wind generator plans, \$15.

Helion and Sencenbaugh also sell kits and completed wind generators.

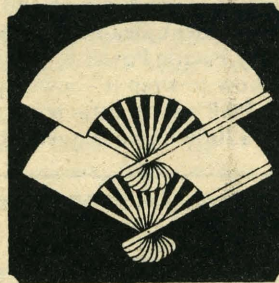

*Simplified Wind Power Systems for Experimenters*, by Jack Park, \$6 from Helion (address above)

Covers basic design, aerodynamics, structural and mechanical design, energy storage for the non-engineer. Graphs, photos, example calculations. Mainly on 3-blade horizontal axis machine designs.

*Windpower Calculator*, by Robert G.

Flower, free with self-addressed, stamped envelope from:

Life Size Aero Design  
P.O. Box 246  
Alburtus, PA 18011

A nomograph for the easy "at-a-glance" figuring wind-plant power output of small- and medium-scale wind machines (i.e. under 40' blade diameter).

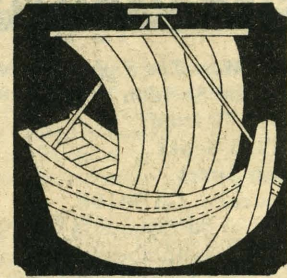

*Wind Power Climatology of the United States* (SAND74-0348), by J. W. Reed, 1975, \$7 from:

NTIS  
Department of Commerce  
Springfield, VA 22151

A wind survey of the entire country which can give you an idea about winds in your area. All suitable data in the National Climatic Center archives for 758 stations have been analyzed for monthly, seasonal and annual average windpower.

*The Vertical-Axis Wind-Turbine: How It Works*, SLA-74-0160, April 1974, by B. F. Blackwell, \$3.75 from NTIS  
Darrieus rotor aerodynamic principles.

*Wind Energy Utilization Bibliography*, Order No. TAC-W-75-700, 1975, \$10 from:

Technology Application Center  
University of New Mexico  
Albuquerque, NM 87131

Annotated, indexed by topic, author, corporate source, permuted title and keyword. If you can only afford one, this is it.

*NSF/RANN Wind Energy Research Reports*, Bulletin No. 3, June 1975, free from:

National Science Foundation  
1800 G St., N.W.  
Washington, DC 20550

*Federal Wind Energy Program Summary*, May 1, 1975, free from:

ERDA  
Division of Solar Energy  
Washington, DC 20545

This tells who, where is doing what work on wind for how much money.

—Lee Johnson





## NUCLEAR POWER

*The Electric War: The Fight Over Nuclear Power*, by Sheldon Novick, 1976, 376 pp., \$12.50 from:

Sierra Club Books  
530 Bush Street  
San Francisco, CA 94108

This book is so outrageous in the story it tells and the comprehensiveness of its telling that Lane has still not gotten to read it, though she ordered it. I could not put it down. Novick provides us with the observations of a passive eye, not the exaggerations or hyperbole of a pro- or an anti-, or of the news muck-raker. We see Thomas Edison, the electrical wizard of Menlo Park, and Sam Insull, his private secretary, as Edison fails and Insull finally wins in the attempt to create the electric-power monopolies we have today. We learn how the Cold War provided the breeding ground for civilian nuclear power's multi-billion-dollar industry. We hear how Creative Initiative formed Project Survival to back nuclear safeguards legislation in Oregon, California and other states. We learn a lot, yet are not told how to decide . . . but come to understand that we must soon do so. For, as Jefferson and Samuel Johnson both have said, when we see experts and concerned citizens on both sides, we know the decision will ultimately be up to all the people. Novick's work is an excellent primer for that decision. (LJ)

"Nuclear Power Facilities in the U.S. 1977," a map; "Safety-Related Incidents at U.S. Nuclear Facilities," a diagram, and "World Nuclear Proliferation and Opposition," a map, are available as a set for \$10 postpaid from:

Special Nuclear Materials  
Eco Graphix  
13 Center St.  
Rutland, VT 05701

All are 17" x 24" reference charts chock-full of useful details. Ask about their bulk rates for organizations. (LJ)

## ENERGY SAVING

*Less Is More*, quarterly newsletter, \$5 per year from:

Alex Wade  
Box 43  
Barrytown, NY 12507

Covers cheaper housing, transportation and food and includes feedback from owner-builders. This is neat stuff. Alex was one of the contributors to *Low-Cost, Energy-Efficient Shelter*, edited by Eugene Eccli, and has continued his work by producing complete working drawings for various energy-conservative,

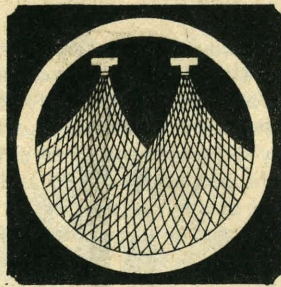

build-it-yourself home designs, including detailed construction notes. The Fall '76 *L.I.M.* contained consumer evaluations of five small cars: Honda Civic, Renault R5, VW Rabbit, Chevette and Subaru; low-cost heating systems; building codes and the energy-efficient houses and other very interesting hints on how to live lightly. Send a self-addressed, stamped envelope for his publication list. (LJ)

*Have a Wrap Session with Your Electric Water Heater*, 4 pp., free from:

Water Heater Wrap  
Conservation Dept.  
Portland General Electric Co.  
121 S.W. Salmon  
Portland, OR 97204

If yours is an *electric* hot water heater located in an *unheated* space, you can save \$15 maximum, \$8-\$10 average, per year on your electric bill. Takes 45 minutes of your time, 1 roll of R-11 (3-1/2") kraft-backed insulation, 15" wide, a 15-yd. roll of duct tape, scissors, marking pen, a measuring tape and gloves. An excellent idea being ably promoted by Pacific Power & Light's full-page "how-to-wrap-it" newspaper ads and by PGE's nifty little red booklet. Easiest \$20/hour we've seen. (LJ)

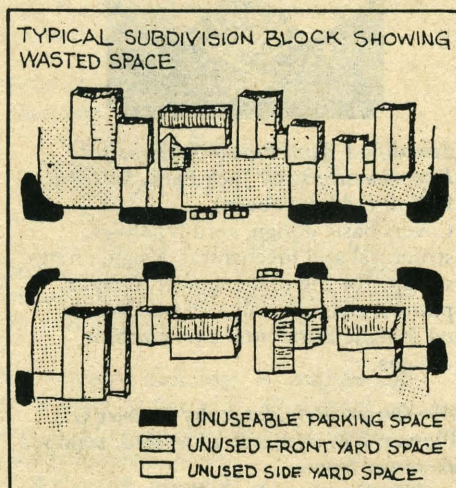

*Planning for Energy Conservation*, \$7.50 from:

Living Systems  
Route 1, Box 170  
Winters, CA 95694

Living Systems has been doing some of

the finest innovative work in energy conservation we've seen. They've recently completed the design of a passive solar heated and cooled office building for the state of California that should reduce energy use in the building by 90%. They've built a number of homes with insulating shutters, water walls and other simple techniques that cause energy use to plummet. *Planning for Energy Conservation* contains a series of city ordinances they've prepared for energy conservation, many of which have already been adopted in Davis, CA. Their new building code reduces energy needed to heat and cool dwellings by 50%. Tree planting ordinances are expected to reduce summer temperatures in the city by 10°F. Ordinances establishing solar zoning, reducing setbacks of buildings (allowing more effective use of land), reducing street widths, setting up bikeways to open lower energy transportation options, allowing work at home, restricting fossil fuel pool heaters and permitting clotheslines (!) are outlined and their effects analyzed. They have also studied many existing buildings in Davis under a HUD Innovative Project Grant, showing how energy use could be significantly reduced in each, and distribute a quarterly *Energy Conservation News* to the residents of the city. (TB)

## COMMUNICATION



*Mass Media Booknotes*, edited by Christopher Sterling, monthly, \$3.50/yr. (\$4.50 overseas) from:

Dept. of Radio-TV-Film  
School of Communications & Theater  
Temple University  
Philadelphia, PA 19122

While basically intended for communications department professors, this monthly 10-page newsletter is chock-full of critical and personal reviews of the latest books in the field of mass communications. Each issue covers publications in media journalism, general mass media, popular culture, law and regulation, telecommunications, and a special feature called "Book of the Month." Especially useful for librarians. And the price is right. (RE)



**The Slide Tape Collective**

36 Lee St.  
Cambridge, MA 02139  
617/492-2949

Janet Goldwater, Sarah Kuhn,  
Stephen Lewis

Community groups who want to use non-print media to tell their story are frequently attracted to film and video and often overlook the less expensive and equally effective vehicles of slides and slide tape to perform the same function. The Slide Tape Collective is the only organization in the country whose purpose is to help people make, distribute and exchange noncommercial slide tape shows.

They have published an excellent guide, *Producing Slide Tapes*, by Stephen Lewis, 1975, \$3. This manual primarily emphasizes technical information: black and white slides, mounting, storage and filing, viewing, rear screen materials, duplication, copying, synchronization of slides and sound, dissolve, and sound.

The Collective is currently compiling a *Slide Show Directory*, the first comprehensive national catalog of noncommercial slide shows. If you have or know of slide shows that should be listed, send them a self-addressed stamped envelope to receive a form for listing. They can also act as a distributor for slide shows. They will make a copy of your show for their library at a cost of 22 cents per slide, plus \$6 per carousel, which they then loan out for free or at nominal cost. (RE)

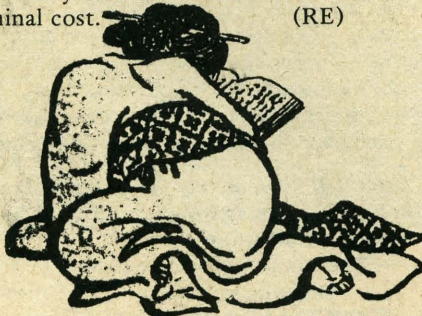

*Feminist Films Available in Portland, Oregon*, Fall 1976, 28 pp., prepared by members of the Women's Resource Center, the National Organization for Women, the Men's Resource Center and the Creative Outlet, free from:

Feminist Films  
Box 843  
Portland, OR 97207  
503/235-3433

A guide to sources of films, videotapes and slide shows (many of them locally produced) on feminist issues available for rental or purchase in the Portland area. This is an excellent first step in making accessible alternate views to traditional roles for women and men through non-print media. Recommended for public schools systems and libraries and as a model for other cities. (RE)

**WHAT IS SLIDE TAPE?**

A slide tape is like a movie with still pictures. It consists of a sequence of slides linked to a narration or sound track which can be as complex as you like—anything from a script read aloud as you change the slides to a prerecorded mix of music, sound and narration.

Slide tape is a good tool for organizing. You can use it to alert people to a community problem. If you are doing door-to-door organizing, you can give showings of a slide tape in living rooms, libraries or schools. Using slides to help emphasize a problem gives you the advantage of visual impact. People will *see* what you mean.

Slide tape is also an educational tool. You can use it to teach people a skill or to describe how to set up a co-op or community newspaper. Teachers can use slide tape to present ideas which scholars, educators and other teachers have condensed into audio-visual form. And slide tape can be a medium for teaching a creative approach to film study, and humanities and esthetics in general.

You'll need to have or borrow a camera, slide projector and tape recorder (if you want a recorded sound track), but the cost of making the slide tape itself is fairly low. You could put together a 30-minute presentation for \$30-\$50.

These are the basic steps in making a slide tape:

1. Organize what you want to show—the text, the images, the music.
2. Photograph the images, scenes, titles using Pan X black and white film, or color slide film.
3. Develop into slides directly in a tank (no darkroom necessary) using Direct Positive Reversal chemicals (available in kit form) and cut and mount in cardboard slide mounts using an iron. The cost is about 6¢ per slide for black and white and 14¢ for color.
4. Prepare narration: written script with indications for slide changes or recorded narration/music/sound on tape impulsed with a synchronizer (\$20-\$50) for automatic playback.

The principal advantages of slide tape are: low cost, ease of editing and change of content, dominance of sound as the primary moving force.

from *Producing Slide Tapes*

*How to Do Leaflets, Newsletters and Newspapers*, Nancy Brigham, 1976, \$1.25 from:

The New England Free Press  
60 Union Square  
Somerville, MA 02143

Straightforward explanation of how simple printing processes work, what they can do and how to prepare material for printing. A handy primer packed with useful information in spite of a somewhat confusing layout. (TB)

*The Library Hands-On Book*, 1974-75, copies available free while they last from:

Jovanna J. Brown  
Dean of Library Services  
The Evergreen State College  
Olympia, WA 98505

A model resource on how to access a library. Written and illustrated with great wit, this information packet speaks in a personal manner to the library user about such exotic subjects as the vertical file, LC classification and interlibrary loan, as well as demystifying reference, acquisitions and cataloging. The text describes not only what services are available but why the library functions the way it does. This is one library that wants to make the riches it has to offer easily accessible to its patrons. (RE)

**GOOD THINGS**

Environmental Action Reprint Service (EARS) Catalogue 50¢ from:  
2239 East Colfax  
Denver, CO 80206  
303/320-6537

Want a handy way to get hold of most alternative energy and major AT materials we mention? Order them from

EARS. Their newest annotated collection is 20 pages packed full of familiar goodies, including papers, books, plans and films. Once on their mailing list, you'll continue to receive their useful catalogues. (LdEM)

*Thoughts, Governor Jerry Brown*, \$2 from:

City Lights Books  
1562 Grant Avenue  
San Francisco, CA 94133

City Lights has published a runaway best seller in this selection of thoughts of California's Governor Jerry Brown. In a period when the grey mush of Washington gets thicker and thicker, it's heartening to feel some real questions being asked and some real attempts being made to find workable ways to do things. A lot of very fine people are assembling in Sacramento. Some good should come of it. These quotes give a sense of the thoughtful questioning and probing behind it. (TB)

*Community Planning Report*, \$65 (\$70 if billed), weekly, from:

Resources News Service  
1046 National Press Building  
Washington, DC 20045

An excellent newsletter focusing on the problems of growth and community, put out by some good folks in Washington D.C. Keeps tab on government hearings, new legislation, upcoming gatherings on the east coast, new regulations published in the Federal Register, recent rulings in the courts, federal research grants and contracts, and a listing of relevant books and resources. Always full of useful information for communities trying to chart a new future. (TB)



# ECONOMICS, ENERGY

*Tax Credits for Employment Rather than Investment*, by Berndt, Kesselman and Williamson, 1975, from:

Institute for Research on Poverty  
University of Wisconsin  
Madison, WI 53715

Present subsidies to large-scale, capital- and energy-intensive industry are substantial and contribute to both unemployment and overproduction of goods in an era of limited resources. Employment tax credits rather than investment tax credits assist substitution of employment for capital and energy, while the removal of all tax credits results in less promotion of unnecessary production. This study finds that removal of investment credits lessens capital demand and probably causes a net increase in employment as well as a shift to greater blue-collar employment. Various employment credits with the same cost as present investment credits would provide 0.5 to 1% increases in employment, 1 to 6% less need for capital and 0.5% increase in prices of output (which would be more than balanced by lower unemployment costs).

*The Energy Dilemma—What It Means to Jobs*, R. Denny Scott, 1976

Department of Research  
International Woodworkers of  
America  
1622 N. Lombard  
Portland, OR 97217

It's encouraging to see such good things coming from labor unions. This union is one of the best and knows what's coming down the road for us. This paper refutes claims made that unemployment will result if increased energy supplies are not obtained, examines effects of automation in reducing employment and explores the myth that energy and GNP and well-being are closely linked. It concludes that economic and employment growth can occur in sufficient quantity to accommodate an expanding workforce without a corresponding historical increase in energy consumption.

*Electricity Consumption and Investment Finance in California*, W. R. Z. Willey, May 1976, from:

Environmental Defense Fund  
2728 Durant Avenue  
Berkeley, CA 94704

Willey explores the investment impacts of alternative means of matching California's future electrical needs and sup-

plies and shows that current projections are economically irrational and environmentally destructive. Improved end-use efficiency would reduce by one-third the investment needed for supply electricity, and a scenario where investment is shifted from the supply to the demand side of the electricity market explores the social and economic impacts of such actions. Energy conservation in end use of electricity is shown to be a lucrative opportunity to the energy investor when compared to the investment opportunities in generation (better show this to your P.U.C. and your local bank), to provide increased employment and a redistributive economic effect.

*The Impact of Solar and Conservation Technologies Upon Labor Demand*, Skip Latimer, May 1976, from:

Public Citizen  
P.O. Box 19404  
Washington, DC 20036

An excellent and well-referenced analysis of the employment benefits of alternatives to conventional power generation. Puts to rest the whole debate about energy and jobs with Herman Daly's well-founded remark that the whole purpose of using non-human energy has always been to replace human labor. Goes on to clarify many issues and show employment increases generated through more efficient appliances, comparative job intensities of nuclear and solar resources (solar technologies provide roughly 2.5 times more jobs per unit of energy than will nuclear), and capital savings of solar industries. Every union and every congressperson should see this.

*Public Pension Funds as a Source of Capital for Job Creation*, Ed Kirshner, Kenneth Baar and Eve Bach, 1975, \$2 from:

Community Ownership Organizing  
Project  
349 62nd Street  
Oakland, CA 94618

Piece-by-piece we discover how pervasively our beliefs in corporate power have focussed all of the energy in our society into their growth. Public pension funds as well as many other major chunks of wealth floating around our society are unquestioningly invested in corporate stock. This paper analyzes the economic and social implications of alternative investment patterns. Investing

pension funds in housing (heresy!) rather than stocks is shown to be less risky, to give greater economic return and to have more positive social impacts. COOP also puts out a good quarterly newsletter called *The Public Works*, which covers many of their activities (free).

*The Cities' Wealth by the Community Ownership Organizing Project*, 1976, \$2.50 (\$5 for institutions) from:

Conference on Alternative State  
and Local Public Policies  
1901 Q Street N.W.  
Washington, DC 20009

The comprehensive programs proposed, fought for and to a degree enacted by the community activist coalition in Berkeley since 1967 provide an important example for other communities. Good programs, the real-live politics of getting changes implemented, the information pried out of the city government on how things have actually been done are all extremely useful. They bring together an exciting picture of how an awakened citizenry has decided they want their city to be. The difficult questions of the city as employer—cutting excessive costs while working for better conditions for the employees on the bottom—are dealt with and examples given of red tape changes that have been made in the bureaucracy itself.

*The Bell System and Community Telephones*, Thomas Brom and Ed Kirshner, 1974, \$1.50 from:

The Community Ownership  
Organizing Project  
349 62nd Street  
Oakland, CA 94618

This was a real eye-opener to me. It made clear why I've felt more than vaguely uneasy about Ma Bell and her minions and their incessant demands on our pocketbooks. It describes the effective and economic operation of the few remaining municipally-owned phone systems—Edmonton, Alberta, for example, that earns 25% more revenue than comparable Bell-owned systems. It also explains some of the financial shell games played with the various Bell-owned "subsidiaries" which result in major overcharges to customers and subsidies of certain favored groups. For instance, Bell buys all its equipment at inflated prices from its subsidiary, Western Electric, since only Ma Bell's return



# AND EMPLOYMENT

on investment is regulated. Revenue from home phone use and local calls supports a limited class of affluent business telephone users who make 2.5 billion interstate calls per year. Training and labor costs are excessive because of Ma Bell's infamous employment practices that result in a 62% yearly turnover of operators—the highest rate in the country. The list goes on and on. Alternatives to the Bell System are explored, as well as the process of getting from here to there. Well worth reading.

**How to Research Your Local Bank,** William Batko, 1976, \$2 from:  
**Institute for Local Self-Reliance**  
 1717 18th Street N.W.  
 Washington, DC 20009

A manual for cities and community residents interested in examining the actions of local financial institutions and the impact they have on local economic development. Explains where and how to obtain information and

what it all means. Specifics on things such as control and ownership—how small banks are not created for the sole purpose of making money but rather to facilitate other business ventures of the bank owners, such as real estate development.

**Competitive Scale in Manufacturing: The Case of Consumer Goods,** Barry Stein and Mark Hodak, 1976, \$1.75 from:

**Center for Community Economic Development**  
 639 Massachusetts Avenue, Suite 316  
 Cambridge, MA 02139

One of the most difficult factors in launching a new business venture by community groups is determining a size of operation that has probability of success but least commitment of financial resources. This study determines the size of new plants that are entering specific markets, calculates the market sizes associated with these new plants, and estimates the least size that is thought

appropriate (by others who have done it) for new plants to enter the market for a product. Very helpful data for anyone considering a manufacturing venture.

**Sources of Capital for Community Economic Development,** Leonard Smollen and John Hayes, 1976, \$10 from:

**Center for Community Economic Development**  
 639 Massachusetts Avenue  
 Cambridge, MA 02139

A very helpful guide for anyone starting out into the maze of finding money to start a community-based business. A key to meanings of jargon and secret passwords, description of an amazing variety of sources for money, what they finance, terms, special loan conditions, etc., as well as a listing of minority-owned and -managed banks and savings/loans and other capital sources.

—Tom Bender

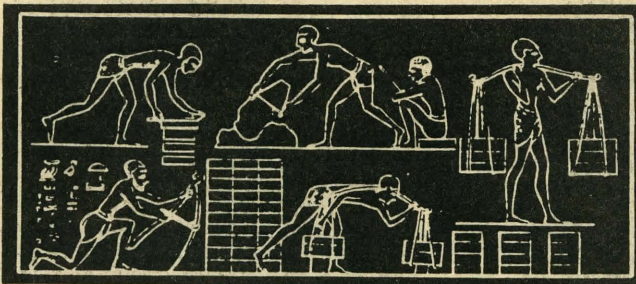

**Energy and Labor Demand in the Conserver Society,** Bruce Hannon, July 1976, from:

**Center for Advanced Computation**  
 University of Illinois Urbana-Champaign  
 Urbana, IL 61801

Quantifies the substantial number of new jobs created through energy-conserving shifts in the structure of the U.S. economy. As well as showing that a great range of energy-conserving options generate jobs, the study shows that electrification of our energy sources results in a loss of approximately 75,000 jobs per quad of primary energy transformed into electricity. (TB)

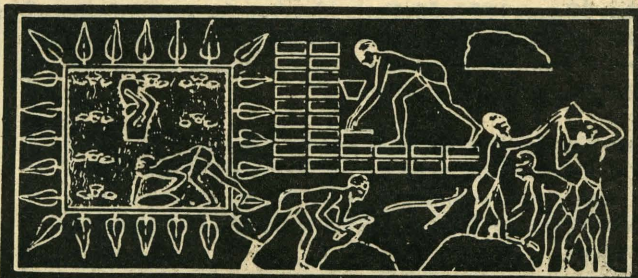

## EMPLOYMENT BENEFITS OF ENERGY CONSERVATION

Project	New Jobs Per Quadrillion BTU Saved
Changing from . . .	
Plane to train (intercity)	930,000
Throwaway to refillable beverage containers	750,000
Car to train (intercity)	700,000
Owner-operator truck to class 1 freight train	675,000
New highway construction to health insurance (federal)	640,000
Car to bus (intercity)	330,000
Car to bus (urban)	210,000
New highway construction to personal consumption	200,000
Car to bicycle	200,000
Plane to car	160,000
Plane to bus	140,000
Electric to gas stove	160,000
Electric to gas water heater	120,000
Electric commuter to car	110,000
Electric to gas clothes dryer	100,000
Frost free to conventional refrigerator	60,000
Plush (25 appliances) to moderately equipped (16 appliances) kitchen	30,000
New highway construction to railroad and mass transit construction	30,000
Present to increased home insulation (oil heat)	15,000
Moderate to spartan (4 appliance) kitchen	10,000





# RAIN PUBLICATIONS



## BACK Issues

Descriptions following each back issue only indicate feature articles contained therein. All issues contain resource listings of groups, activities, events, books and periodicals on a wide variety of subjects: appropriate technology, agriculture, food, community, energy, shelter, maps, conservation, economics, health, land use, learning, small business, communications, sewage, media, recycling, whole systems, self reliance, networking, environment, transportation, consciousness and good things.

**I, 7 (Apr. '75)** Roughdraft III: Centers/NW Environmental Groups Update/"Sharing Smaller Pies" excerpt by Tom Bender

**I, 8 (May '75)** Roughdraft IV: Networking/Small Industry Development Network/Self-Sufficiency, Energy, Rural Skills, Schools and Programs

**II, 2 (Nov. '75)** Free Tree Energy/"On Inflation" by E. F. Schumacher/NW Energy Directory/Too Many Books and Too Few (alternate library literature)/Paths to a Solar Transition/The World from Above (maps)/Touch & Go

**II, 4 (Jan. '76)** Eating High and Lightly/Towards a Federation of Ecotopian Nations/Wood Cook Stove Selection and Repair/The Great Recycling Race (the ORE plan)/Seven Laws of Money excerpt by Michael Phillips/Touch & Go

**II, 6 (Apr. '76)** Special poster issue: Visions of Ecotopia/Goodbye to the Flush Toilet/Make Where You Are Paradise/Dollar Power

**II, 7/8 (May '76)** Country Auctions/Red Star Over China/What's Growing in Iowa/Capturing the Sun Through Bioconversion/Small Scale Computer Activities

**II, 9 (June '76)** Special Northwest Habitat issue: Rural roots/Information Springs/Community Building/Community Inventories/Energy

**II, 10 (July '76)** "Plant a Tree" by E. F. Schumacher/Natural Land Inventories/In Touch: Community Communications Access/Passive Solar Systems/Spirit and Space/Women & Health

**III, 1 (Oct. '76)** Pleasant Undertaking by Malcolm Wells (on simple burial)/Appropriate Technology Update/Pedal Power by S. S. Wilson/Cycle Discoveries/Pioneering Communities by Dulcie Brown/Costs of Tourism

**III, 2 (Nov. '76)** Tofu & Miso (eating high and lightly)/Stolen Goods by Tom Bender/Wood Stove Consumer's Guide by Bill Day/Place



## Other Publications:

**Solar Workshop Manual**, by Lee Johnson & Ken Smith of Ecotope Group, 15 pp., with photos and diagrams, September 1976, \$3. Step-by-step instructions, material and tool lists and plans for a do-it-yourself solar hot water heating system with 60 sq. ft. of solar collector; adaptable to existing gas or electric home hot water heaters and costing \$250-\$350 wholesale in materials. Based on the authors' experiences conducting solar workshops throughout the Pacific Northwest.

**Woodstoves**, Rainpaper No. 1, November 1976, \$1. Compiled reprints from articles by Bill Day on selection, maintenance and repair of woodstoves of all kinds. Bill is a third-generation repairer of woodstoves who owns a store in Portland, Oregon.

**O.A.T. Bibliographies**, August 1966, 50¢ apiece. A series of resource lists prepared for the California Office of Appropriate Technology. Each annotated bibliography runs two to five pages and contains overviews, technical evaluation, models, how-to and access information. Bibliographies available on the following topics: Direct Solar Heating Cooling, Energy Conserving Landscaping, Wind Energy, Solid Waste Utilization, Drying Up the Toilets, Diseconomies of Scale, Bioconversion: Methane Production, Weatherizing: Home Insulation, Costs of Urban Growth, Natural Pest Control, Appropriate Technology, Low-Cost Construction.

**Coming Around: An Introductory Sourcelist on Appropriate Technology**, prepared by Lane deMoll, 12 pp., revised edition, September 1976, \$1. A general listing including general theory, economics, and energetics, community, manufacturing, tools and hardware, financial institutions, agriculture, health care, shelter, transportation, self-reliance and energy. Does not include how-to publications but directs you to them.

**Employment Impact Statement**, October 1976, 2 pp., 50¢. A simple, step-by-step way to figure the employment impacts of a new industry and consider the benefits of different options.

**Ecotopia Poster**, by Diane Schatz, 2'x3', \$3. A reprint of the "Visions of Ecotopia" line drawing that appeared in the April '76 poster issue. Great for coloring.

**Environmental Design Primer**, by Tom Bender, 206 pp., 1973, \$5. Meditations on an ecological consciousness. Essays and poetry about moving our heads into the right spaces before our places.

**Living Lightly: Energy Conservation in Housing**, by Tom Bender, 38 pp., 1973, \$2. Early ideas on the need for change in building and lifestyle; compost privvies, Ouroboros Project (self-sufficient experimental house in Minnesota) and the "problem of bricks in your toilet."

**Sharing Smaller Pies**, by Tom Bender, January 1975, 38 pp., \$2. Discussion of the need for institutional change tied in with energy and economic realities. Begins to lay out new operating principles, including some criteria for appropriate technology.



# GOOD THINGS

Acorn/Midwest Energy Alternatives Network

Governor's State University  
Park Forest South, IL 60466  
312/534-5000

Bethe Hagens and Jim Laukes are well on their way to spearheading a strong network of people involved in energy and technology alternatives in the Great Lakes region. Their newsletter—getting better by leaps and bounds—costs \$6/yr. for individuals and \$10 for institutions for six bi-monthly issues. The latest (No. 4) had articles on passive solar orientation and design, federal grants availability, advocacy and environmental impact statements, and lots of access information. I came away with quite a few new hits. If you live in their region or are interested in what other regions are up to, you should definitely be in touch. (LdeM)

*Seriatim*—*Journal of Ecotopia*, \$9/year in the Northwest, \$12 elsewhere, quarterly from

*Seriatim*  
P.O. Box 117  
McMinnville, OR 97128

*Seriatim* does exist now, and the first issue contains 96 pages of articles by or on Ernest Callenbach, Joel Schatz, logging, the ORE Plan, energy conservation, natural farming, etc. It doesn't seem to bring much new light on the topics it covers or open new territories, but hopefully that will happen as it develops. Good regional publications are



# RAIN DROPS

When we raised our prices in May, we eliminated the "institutional" subscription, which provided for three copies of each issue. If you would like multiple copies to the same address each month, write and ask about special rates.

If you write to us at RAIN and don't want your letter printed as you wrote it, please say so. We don't print all letters, but if one is pertinent to a topic, we'd like folks to see it. And if you write to anyone we mention in RAIN and want an answer, please include a self-addressed, stamped envelope, often abbreviated SASE.

When a subscriber moves, it costs us about 50¢ to change our three sets of file cards (alphabetical, zip code and expiration date order, in case you wondered). That's an inevitable cost of maintaining a current mailing list. But when a subscriber depends on the Post Office to notify us of an address change, we pay them 25¢ for the notification (even if it's only "moved, left no address"). And the PO usually returns the unread copy of RAIN to us. It would then cost us another 13-24¢ postage to remail it. So we ask that if you want any issues you missed by moving, please be willing to order them and pay a dollar each. And if at all possible, let us know *before you move* so we can avoid your missing them in the first place. Making friends with your mailman also helps. (AM)

vital resources, and those such as *Maine Times* (and hopefully *Seriatim* as it evolves) are proof of what importance they have and what they can contribute. Take a look for yourself. (TB)

RAIN's office is at 2270 N.W. Irving, Portland, OR 97210. Phone (503) 227-5110.

<i>RAIN Staff</i>	Marcia Johnson
Tom Bender	Lee Johnson
Steve Johnson	Lane deMoll
Rhoda Epstein	Anne McLaughlin

Typesetting: Irish Setter  
Printing: Times Litho

Thanks to: Lauri deMoll

# SUBSCRIBE TO RAIN

Subscriptions begin with future issues only; back issues must be ordered separately.

Name \_\_\_\_\_  
Address \_\_\_\_\_  
Zip \_\_\_\_\_

The Post Office won't deliver magazines without zip codes.

- New Subscription
- Renewal
- Change of Address
- Please don't include my name when you exchange *RAIN's* mailing list.

Occupations/Preoccupations:

Interests/Concerns:

Where did you hear about *RAIN*?

Inquire for multiple copy rates.

\*PLEASE ENCLOSE PAYMENT: If we have to bill you, add \$5 to above rates.

*RAIN Magazine* · 2270 N.W. Irving · Portland, OR 97210

## SUBSCRIPTION RATES:

- Regular — \$10/10 issues
- Living Lightly — \$5/10 issues (income less than \$5,000 . . . ?)

## ADD POSTAGE OUTSIDE U.S.A.:

- CANADA/MEXICO:
- \$2.50/yr., Printed Matter rate
  - \$4/yr., First Class rate

## OTHER FOREIGN:

- \$2.50/yr., 2-month surface mail
- \$4.50/yr., 5-week first class
- \$16.50/yr., 1-week airmail

## OPTIONAL FIRST CLASS MAIL IN U.S.A.:

- \$3/yr., for quicker delivery east of the Rockies.

AMOUNT ENCLOSED \$ \_\_\_\_\_



# Rush

Habitat One, a solar- and wind-powered house at the University of Massachusetts, is expected to officially open in November. Information is available from: Duane E. Cromack, Mechanical Engineering Lab No. 7, University of Massachusetts, Amherst, MA 01003 □ Also, a number of workshops on alternative energy and related topics are offered at U Mass through the Division of Continuing Education. Contact: Merilee Neunder, Division of Continuing Education, University of Massachusetts, Amherst, MA 01003 □ Working drawings on the IRR1 diaphragm water pump (RAIN, Oct. 1976, p. 9) are now available from the International Rice Research Institute, P.O. Box 933, Manila, Philippines □ *Wanted: persons who have chosen to work less than a five-day week to participate in work/play balance study. Please send resume and address to: Calico Mountain Exploratory and Woodworks, Route 2, Box 287A, Portland, OR 97231* □ The 1977 Family Energy Watch Calendar is here. Chock full of useful ideas, facts and figures. Available for \$1.50 from: Department of Energy, 528 Cottage St., N.E., Salem, OR 97310 □ *The Boston Women's Health Book Collective (Box 192, West Somerville, MA 02144) is putting together a super collection of Xeroxed reprints on women's health issues from all over. Heavy-duty reading for \$6 a month. Send them articles or papers you want to get spread around* □ There's a lot from Massachusetts this time. The energy must be flowing well from that part of the world. Right now

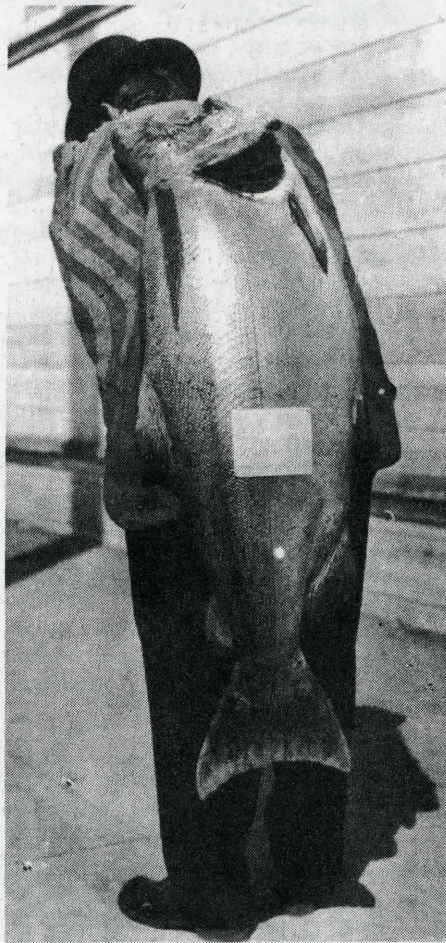

there's a meeting going on of the AT Network in New England. We'll have a first-hand report on that next issue □ *Here's something else: Secretary of*

*Consumer Affairs for the State of Massachusetts, Christine B. Sullivan, has called on the Chairman of the Board of Exxon immediately to withdraw a magazine advertising campaign to mislead American consumers about solar energy. Sullivan protested "the hundreds of thousands of dollars Exxon is spending," and further insisted that Exxon "correct the impressions created by the advertisement." Write for the whole press release and thank her for giving it to those guys: Executive Office of Consumer Affairs, One Ashburton Place, Boston, MA 02108* □ "Geothermal Energy" by Richard Bowen, an OMSI Energy Center lecture, 7:30 p.m., Thursday, Dec. 9 in Arend Auditorium. Fee payable at the door: OMSI members \$2; nonmember \$3; high school and college students \$1. Please register by phone in advance. Call 248-5920 and leave your name. Richard Bowen, a Northwest authority on geothermal energy, considers it a resource of major magnitude with a high net efficiency, as abundant as solar energy and more readily available. He will discuss present applications of geothermal energy in Oregon and the world for electric power generation, space heating and industrial process heat. □ *Shelterforce is compiling a directory of tenant associations and other housing activist groups. Organizations should send name, address, phone and a brief description of their work to: Shelterforce Collective, 31 Chestnut St., East Orange, NJ 07018. Shelterforce is a national housing publication published quarterly, \$3/yr.*



RAIN  
2270 N.W. Irving  
Portland, OR 97210  
*Address Correction Requested*

Non-Profit Org.  
U.S. Postage  
**PAID**  
Permit No. 1890  
Portland, OR